

S45 AUTOMATE 3.0Nm | 35mm

The motorized S45 roller shade system offers a range of four Automate motors with three tube diameters to suit a variety of applications. Featuring ARC (Automate Radio Communication), the 35mm S45 Automate system provides an intelligent, Li-ion battery or DC powered solution.

AESTHETICAL FEATURES

- Slim and compact roller shade system
- Contemporary design

PRODUCT FEATURES

- Easy-Lock effortless installation
- Easy limit setting and programming

FUNCTIONAL FEATURES

- Levelling control
- Simple limit setting and adjustment
- Favorite position
- 3 operational speed settings
- 2-way RF communication
- ARC protocol for simple programming

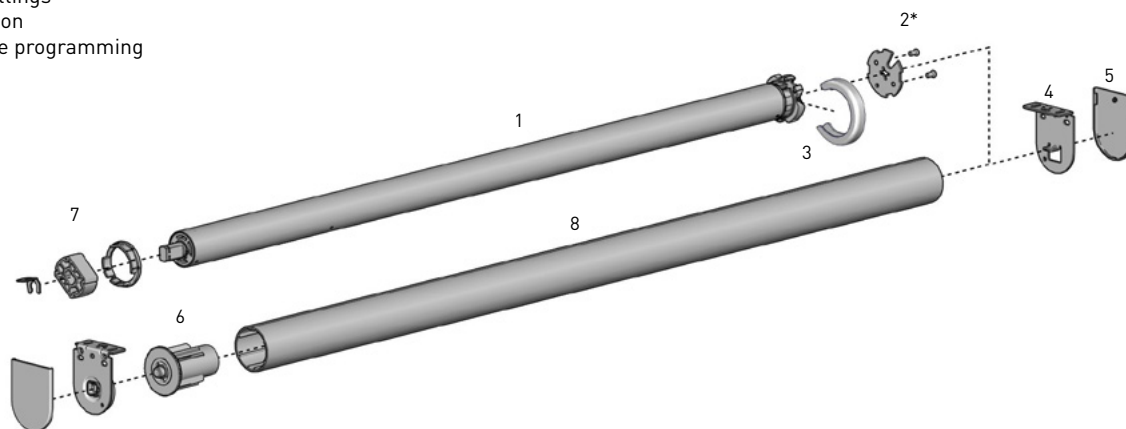

SYSTEM INDEX

	Automate Wirefree Motor MTDCBRF35-3 - Li-ion Q3.0 MTDCRF35-3 - DCRF 3.0 MTACRF35-6 - ACRF 6 MTACQRF35-6 - ACRF Q6
3	Motor Cap MTCAP35xx
	Brackets RB40-8355-xxx040 RB40-9355-xxx040
5	Bracket Covers RB08-4151-xxx040
6	Pin End RB09-0245-xxx001
7	Crown & Drive Set MTCRDR-35-S45
	T-Spline Aluminum Tubes RB93-044#-000490 RB93-644#-000490
9	Adapter RB40-1402-069400
10	Screws for Adapter SLAMSCREW

- Size
xxx= Color

COLOUR RANGE

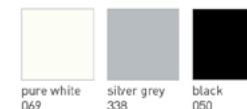

SYSTEM UPGRADES

- CF90 CASSETTE
- CF90 EDGE
- LINK SYSTEM

CONTROL OPTIONS

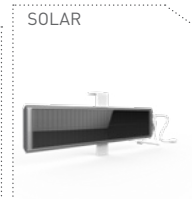

PRODUCT OPTIONS



SPECIFICATIONS

SYSTEM CAPACITY

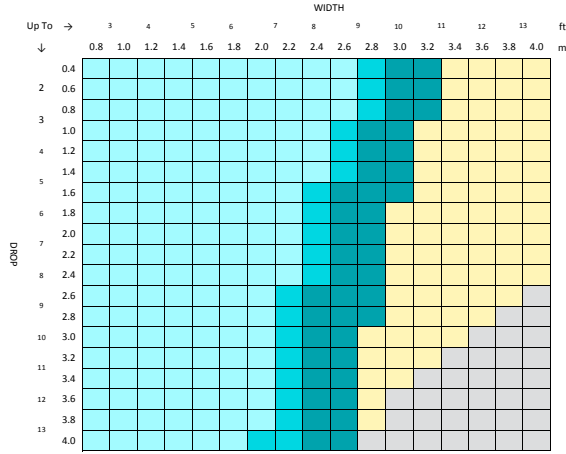

Fabric Thickness: 0.024" [0.60mm]
 Fabric Density: 12.39oz/yd² [420gsm]
 Weight Bar: D30 Silent Medium Aluminium Bottom Rail

CONTROL	TUBE	LINK SYSTEM
25mm Motor	S45 LIGHT	1.5" ONLY
	S45 STANDARD	
	S45 HEAVY DUTY	
	OUTSIDE SPECIFICATIONS	

DEDUCTION CHART

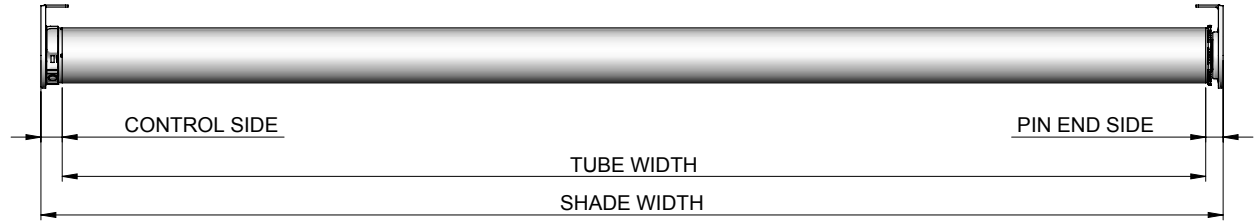

MOTOR	TORQUE	BRACKETS	LIGHT GAP			MINIMUM SHADE WIDTH
			CONTROL END	PIN END	OVERALL	
MTDCBRF35-3 MTDCRF35-3 MTACRF35-6 MTACQRF35-6	3.0Nm	With Covers	0.67" [17mm]	0.55" [14mm]	1.22" [31mm]	2.60' [0.800m]
	3.0Nm		0.63" [16mm]	0.51" [13mm]	1.14" [29mm]	2.00' [0.600m]
	6.0Nm	No Covers				2.40' [0.730m]
	6.0Nm					2.30' [0.700m]

TUBE DEDUCTION = BLIND WIDTH - (CONTROL END LIGHT GAP + PIN END LIGHT GAP)

MAX ROLL

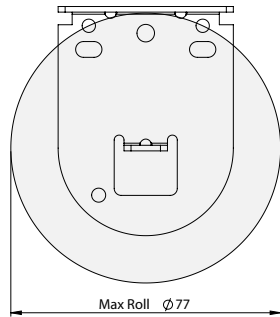

BRACKET	MAX ROLL SIZE
RB09-8355-xxx040	3.03" [77mm]
RB09-9355-xxx040	3.03" [77mm]

TUBE SPECS.

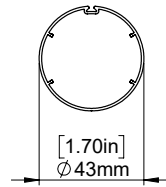

S45 Light Tube

Code RB93-0443-000490
 w. tape RB93-6443-000490
 Length 16' [4.88m]

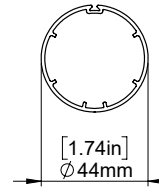

S45 STD Tube

Code RB93-0444-000490
 w. tape RB93-6444-000490
 Length 16' [4.88m]

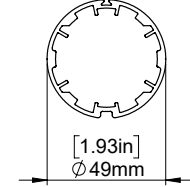

S45 HD Tube

Code RB93-0449-000490
 w. tape RB93-6449-000490
 Length 16' [4.88m]

MOTOR	MAX LIFTING CAPACITY			MAX DROP**
	S45 LT	S45 STD	S45 HD	S45
1.1Nm	11.46lbs [5.2kg]	11.24lbs [5.1kg]	10.14lbs [4.6kg]	13.12' [4.0m]

** Exceeding this value may cause fabric tracking issues