



# Easy Spring Air

## **ASSEMBLY MANUAL**

v1.3 | June 2026



# CONTENTS

<b>SECTION A   SYSTEM DETAILS</b>	<b>3</b>
OVERVIEW.....	3
SYSTEM OPTIONS .....	4
BOM & CUTTING LIST .....	5
<b>SECTION B   PREPARATION</b>	<b>6</b>
FABRIC PREPARATION .....	6
<b>SECTION C   ASSEMBLY</b>	<b>6</b>
IDLER ASSEMBLY .....	6
VISUAL CHECK .....	6
CONTROL ASSEMBLY .....	8
VISUAL CHECK .....	8
<b>SECTION D   PRE-TENSION</b>	<b>9</b>
PRE-TENSIONING .....	9
SPRING CAPACITY CHART   420GSM   1.5" TUBE .....	10
SPRING CAPACITY CHART   350GSM   1.5" TUBE .....	11
SPRING CAPACITY CHART   220GSM   1.5" TUBE .....	12
SPRING CAPACITY CHART   155GSM   1.5" TUBE .....	13
SPRING CAPACITY CHART   420GSM   2" TUBE .....	14
SPRING CAPACITY CHART   350GSM   2" TUBE .....	15
SPRING CAPACITY CHART   220GSM   2" TUBE .....	16
SPRING CAPACITY CHART   155GSM   2" TUBE .....	17
<b>SECTION E   PREPARE &amp; PACK ASSEMBLIES FOR INSTALLATION</b>	<b>18</b>
OPEN SYSTEM.....	18
CASSETTE SYSTEM .....	18

## DISCLAIMER

### INTRODUCTION

This Assembly manual for Easy Spring Air System has been produced by Rollease Acmeda to supply the necessary information for the safe and correct assembly of Easy Spring Air System.

### DISCLAIMER

Rollease Acmeda has used reasonable care in preparing the information included in this document, but makes no representations or warranties as to the completeness or accuracy of the information. Information is supplied upon the condition that the persons receiving the information will make their own determination as to its suitability for their purposes prior to use. Rollease Acmeda assumes no liability whatsoever for any damages incurred by you resulting from errors in or omissions from the information included herein. Rollease Acmeda reserves the right to make changes without further notice to any products to improve reliability, function or design.

### COPYRIGHT

COPYRIGHT © ROLLEASE ACMEDA

All rights are reserved. No part of this document may be reproduced or utilised in any means, by any means, electronic or mechanical including photocopying, recordings, or by any information storage or retrieval system, without the express permission from Rollease Acmeda.

**OVERVIEW**

GENERAL SCHEMATIC

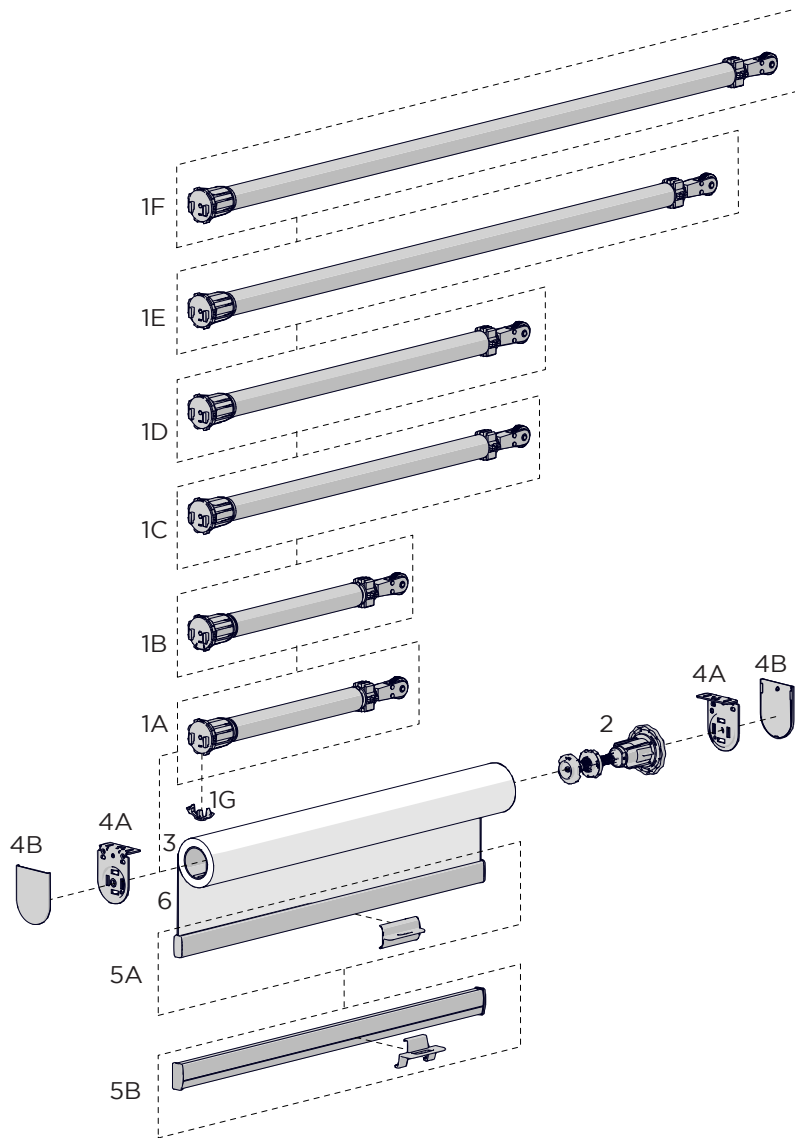

SYSTEM INDEX:

**1. CONTROL:**

- A - Easy Spring Air Micro
- B - Easy Spring Air Mini
- C - Easy Spring Air Small
- D - Easy Spring Air Light
- E - Easy Spring Air Medium
- F - Easy Spring Air Heavy
- G - Tension Lock

**2. LIMITER:**

- Limiter: Single Stop | Universal
- HD Pin End (*Only for 2" Tube*)

**3. ALUMINIUM TUBE:**

- 1.5"
- 2" (*Use 2" Adapter & HD Pin End*)

**4. BRACKETS:**

- A - Bracket: Skyline LX
- B - Bracket Cover: LX

**5. WEIGHT BAR:**

- A - Opulence + Handle
- B - D30 Bottom Rail + Handle

**6. FABRIC:**

- *See Textstyle*

**7. 2" TUBE ADAPTER SET**

- (*optional - not shown*)

TOOLS REQUIRED

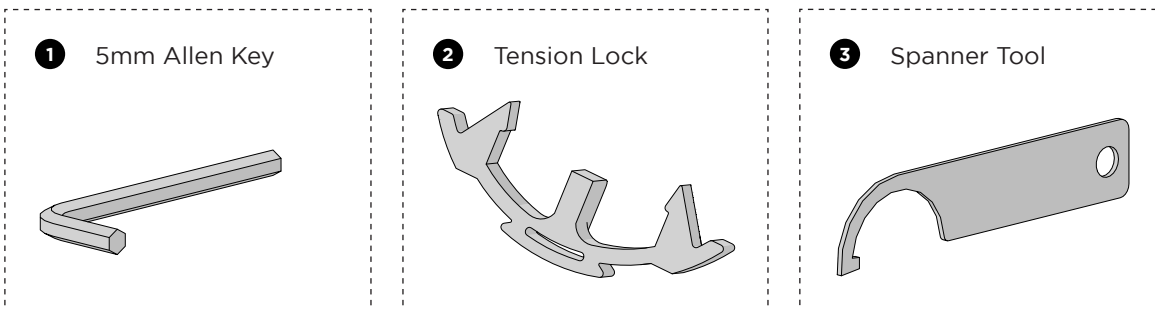

**SYSTEM OPTIONS**

TUBE OPTIONS

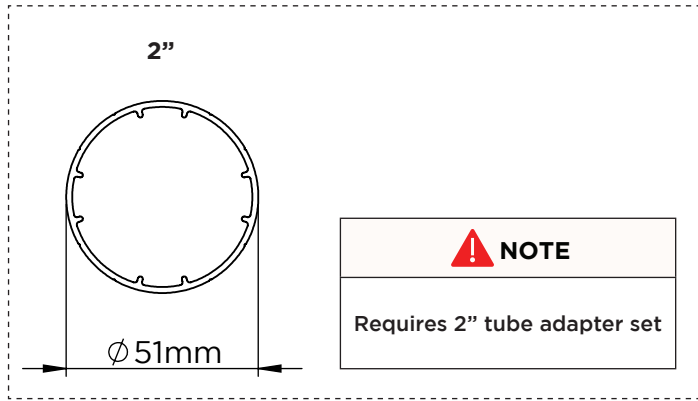
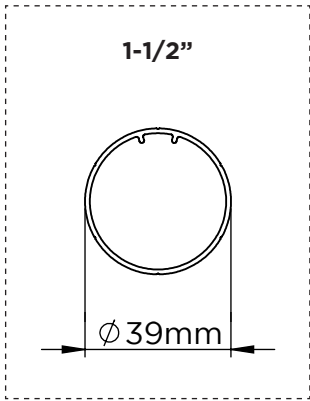

SYSTEM

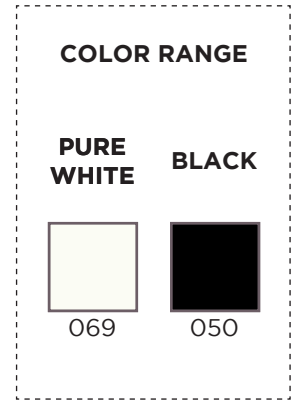

SYSTEM UPGRADE OPTIONS

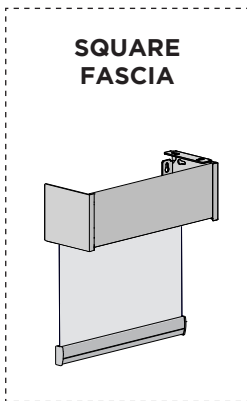
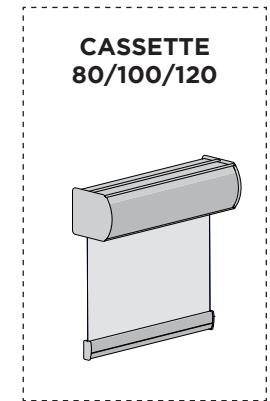
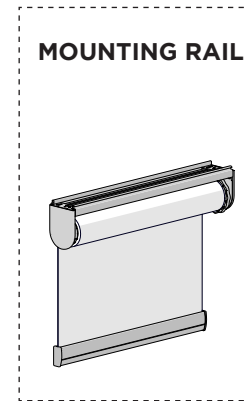
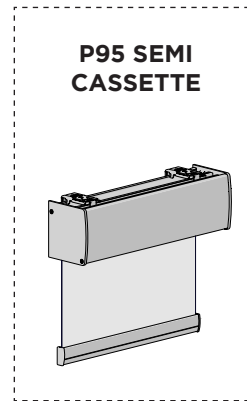
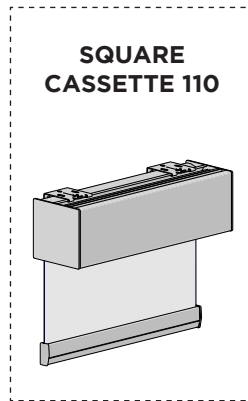
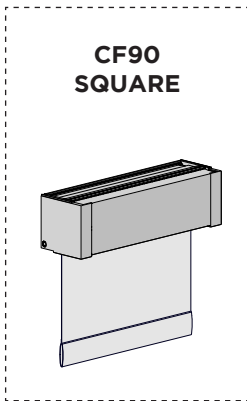

WEIGHT BAR & HANDLE OPTIONS

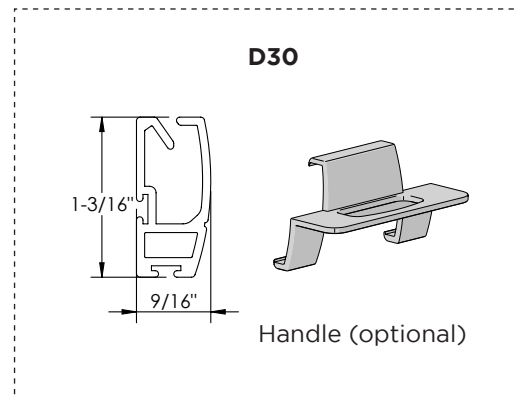
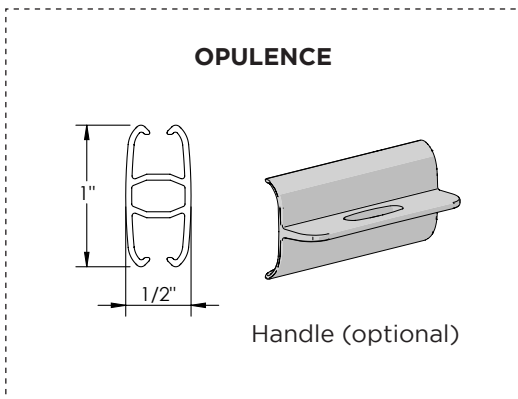

## BOM &amp; CUTTING LIST

PART NUMBER	DESCRIPTION	U.O.M	QTY	DEDUCTION
-------------	-------------	-------	-----	-----------

					OPEN*/CASSETTE 110		
					LX SKYLINE BRACKET		
					HD PIN END	LIMITER (For 1.5" only)	
INSTALL	OPEN BLIND	SL01-0306-xxx040	LX Skyline Bracket	Piece	2		
		RB08-4151-xxx040	LX Bracket Covers	Set	1		
	CASSETTE 110	SB20-0504-xxxLLL	Medium Square Cassette Headrail	Piece	1	W - 5mm [0.197"] (If using covers)	
		SL01-0306-xxx040	LX Skyline Bracket	Piece	2		
		SB20-0503-xxx000	End Cap - Medium Square Cassette	Set	1		

CONTROL OPTIONS	BOOSTER	RB12-3828-xxx038	Easy Spring Air - MICRO w Adjust - 1.5" LH	Piece	1		
		RB12-3831-xxx038	Easy Spring Air - MINI w Adjust - 1.5" LH				
		RB12-3829-xxx038	Easy Spring Air - SMALL w Adjust - 1.5" LH				
		RB12-3832-xxx038	Easy Spring Air - LIGHT w Adjust - 1.5" LH				
		RB12-3833-xxx038	Easy Spring Air - MED w Adjust - 1.5" LH				
		RB12-3834-xxx038	Easy Spring Air - HEAVY w Adjust - 1.5" LH				
	RS01-0107-xxx050	Easy Spring Air Adapter kit, 2"	Piece	0 or 1			
	LIMITER/IDLER	RB12-6101-xxx038	Limiters - Single Stop   Universal 1.5"	Piece	1		
		RB12-6102-xxx038	Limiters - Single Stop   Universal Short 1.5"				
		SLPEHD53xx	Skyline Heavy Duty Pin End 1-1/2"				
RA2xx		Adapter 2" (For Pin End only)	Piece			0 or 1	

BOTTOM RAIL	RB91-1236-xxxLLL	Fabric Wrap Bottom Rail	mm [inch]	1	W - 27mm [1.06"]	W - 32mm [1.26"]
	RB91-1232-xxxLLL	D30 SILENT Medium Bottom Rail				
	RB91-2332-001000	D30 Bottom Rail Handle	Piece	1		
	RB91-2136-xxx000	FW Bottom Rail End Caps	Set	1		
	RB91-2131-xxx002	D30 Medium Bottom Rail End Caps LH & RH				
	RB92-150x-001LLL	15mm Flat Spline	mm [inch]	1	W - 27mm [1.06"]	W - 32mm [1.26"]
	RB92-0903-001075	ACM Flat Spline - 9mm				
	SS91-5350-069000	Smooth Round Spline 5.0mm				
	RB91-2336-001000	Fabric Wrap Hem Bar Handle	Piece	1		
	RB91-2536-069000	Bottom Rail Handle Pull Hook	Piece	1		
VB05-0301-xxxLLL	Base Rail Weight Rod	mm [inch]	1	Refer to the calculator		

TOOLS / ACCESSORIES	RB12-3836-025000	Easy Spring Air - PreTension Tool (Hex)	Piece	1		
	RB12-3835-503038	Easy Spring Air - Tension Lock	Piece	1		
	RB12-3837-025000	Easy Spring Air - Spanner Tool	Piece	1		

TUBE	RTEA4Txx	Rollease Tube + M/P Tape   1.5"	mm [inch]	1	W - 27mm [1.06"]	W - 32mm [1.26"]
	RTEA5Txx	Rollease Tube + M/P Tape   2"				

FABRIC	See Textstyle	Fabric Width	mm [inch]	1	W - 27mm [1.06"]	W - 32mm [1.26"]
		Fabric Drop			D + 150mm [5.9"]	

\*No Covers - If covers required add an extra 2mm [0.08"] to deduction, ie. (W-32mm [1.26"]) = [ W-(32mm [1.26"])+2mm [0.08"]) = W-34mm [1.34"]]

FABRIC PREPARATION

**1** Attach fabric onto tube if using double sided tape

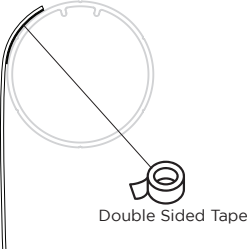

Double Sided Tape

**NOTE**

Minimum 2 full wraps of fabric on the tube

**2** Secure spline for weight bar

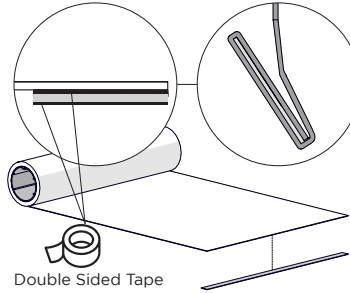

Double Sided Tape

**NOTE**

Use staples when using one wrap on the spline

IDLER ASSEMBLY

**NOTE**

- For a 2" tube, use an HD pin end in place of the limiter.
- You can set either the top limit OR bottom limit.

TOP LIMIT & BOTTOM LIMITS

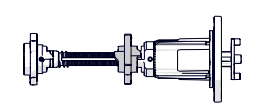
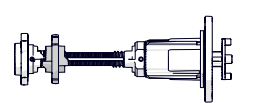
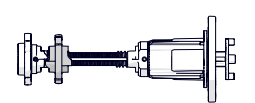
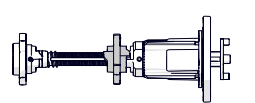
SHADE CONTROL	BACK ROLL		FRONT ROLL	
	Top Limit	Bottom Limit	Top Limit	Bottom Limit
Left				

SETTING BOTTOM LIMIT

**1** Roll the shade to its bottom limit position

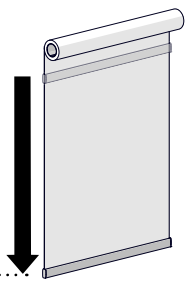

Bottom Limit

**2** Move the limiter slider to its bottom limit

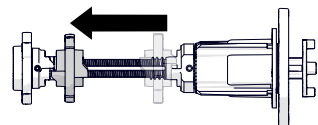

*This example is for back roll left hand control bottom limit.*

**3** Insert the limiter into the tube

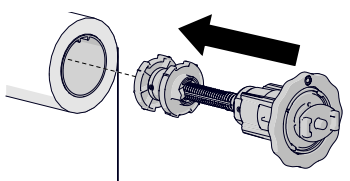

**VISUAL CHECK**

**NOTE**

Ensure that the fins are correctly aligned with the tube.

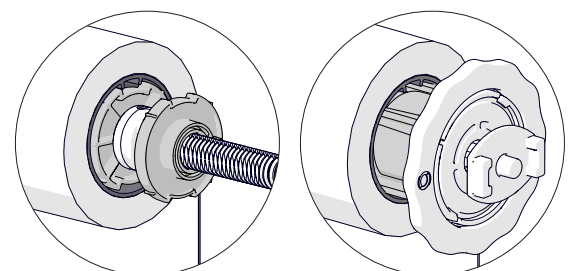

**4** Hold the limiter and roll the shade up

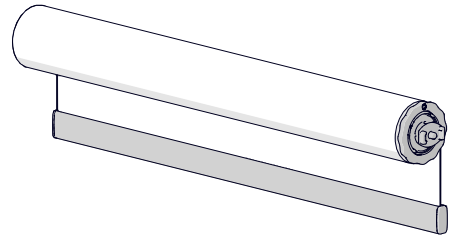
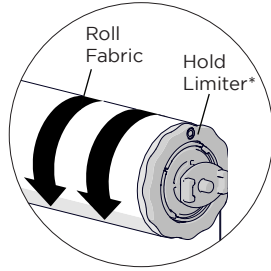
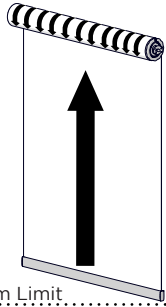

... Bottom Limit .....

\*Ensure the limiter does not rotate while rolling the fabric.

## SETTING TOP LIMIT

**1** Move the limiter slider to its top limit

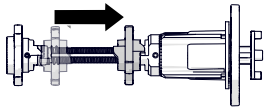

*This example is for back roll left hand control top limit.*

**2** Insert the limiter into the tube

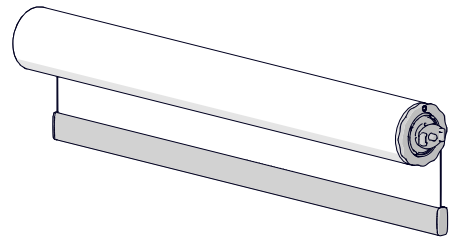
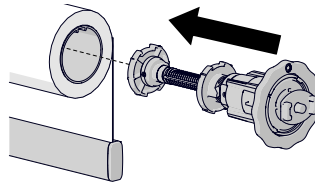

## CONTROL ASSEMBLY

### BOOSTER SIZES

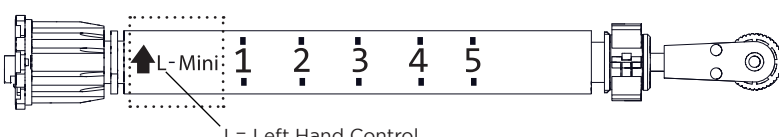

L-Micro	Micro
L-Mini	Mini
L-Small	Small
L-L	Light
L-M	Medium
L-H	Heavy

### SETTING SPRING RATE

**1** Set the spring size by rotating the booster wheel to move the slider. Align left edge of the slider to the appropriate spring size.

**NOTE**

Illuminating the back of the booster will make it easier to locate the slider position.

Use spring calculator/charts to find out the size of your spring.

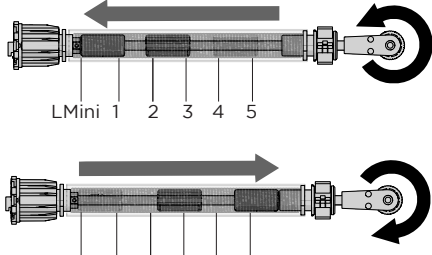

**2** For 1.5" tube, align and insert the booster into the shade

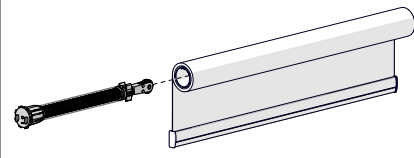

**VISUAL CHECK**

**NOTE**

Ensure that the fins are correctly aligned with the tube.

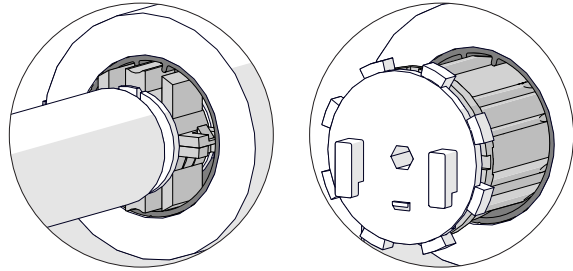

**3a** For 2" tube, align and insert the 2" adaptor into the booster.

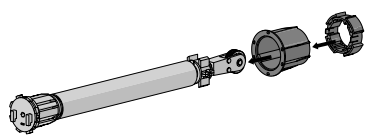

**3b** Insert the booster into the shade.

**NOTE**

Booster must not be pre-tensioned

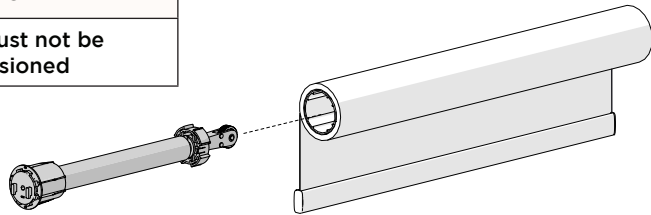

## PRE-TENSIONING

- 1 Rotate spring control using allen key

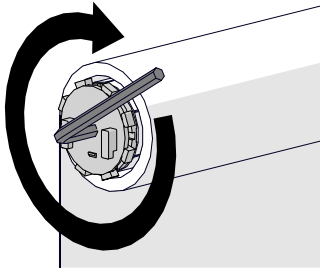

**! PRE-TURNS CHECK**

Use the spring calculator or spring capacity chart to find out the number of pre-turns required.

**! DIRECTION OF PRE-TURNS CHECK**

**LH Back Roll**  
Clockwise

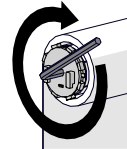

**RH Front Roll**  
Clockwise

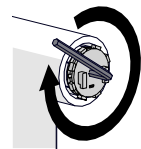

- 2 Attach Tension Lock

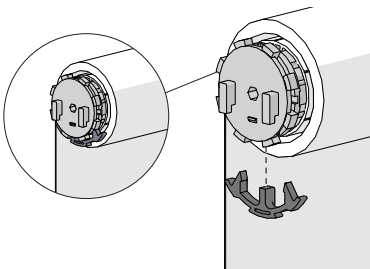



**SPRING CAPACITY CHART | 420GSM | 1.5" TUBE**

420gsm | 1.5" Tube

		WIDTH														
m		0.40	0.60	0.80	1.00	1.20	1.40	1.60	1.80	2.00	2.20	2.40	2.60	2.80	3.00	
DROP	0.60	5 / 7	13 / 10	13 / 12	12 / 14	10 / 14	8 / 14	7 / 14	6 / 13	24 / 14	22 / 14	20 / 14	18 / 14	17 / 14	16 / 14	24
	0.80	5 / 7	13 / 10	13 / 13	11 / 14	9 / 14	8 / 14	7 / 14	6 / 14	23 / 14	21 / 14	19 / 14	18 / 14	16 / 14	29 / 14	31
	1.00	5 / 7	13 / 10	13 / 13	11 / 14	9 / 14	8 / 15	7 / 15	25 / 14	23 / 14	21 / 15	19 / 14	17 / 14	16 / 14	28 / 14	39
	1.20	5 / 6	13 / 10	13 / 14	11 / 15	9 / 15	8 / 15	7 / 15	25 / 15	22 / 15	20 / 15	19 / 15	17 / 15	16 / 15	28 / 15	47
	1.40	5 / 6	13 / 11	13 / 14	11 / 15	9 / 15	8 / 16	25 / 14	25 / 15	22 / 15	20 / 15	18 / 15	17 / 15	29 / 15	27 / 15	55
	1.60	5 / 6	13 / 11	13 / 15	11 / 16	9 / 16	7 / 14	25 / 14	24 / 15	22 / 16	20 / 16	18 / 16	16 / 15	29 / 16	27 / 15	63
	1.80	5 / 6	13 / 11	13 / 16	11 / 17	9 / 17	25 / 13	25 / 15	24 / 16	21 / 16	19 / 16	18 / 16	16 / 16	28 / 16	26 / 16	71
	2.00	5 / 6	13 / 12	13 / 16	10 / 16	9 / 17	25 / 13	25 / 15	23 / 16	21 / 16	19 / 16	17 / 16	16 / 16	28 / 16	26 / 16	79
	2.20	5 / 6	13 / 12	13 / 17	10 / 16	25 / 11	25 / 14	25 / 16	23 / 17	21 / 17	19 / 17	17 / 17	16 / 17	28 / 17	26 / 17	87
	2.40	5 / 6	13 / 12	13 / 18	10 / 17	25 / 12	25 / 14	25 / 17	23 / 17	20 / 17	18 / 17	17 / 17	29 / 17	27 / 17	25 / 17	94
	2.60	5 / 6	13 / 13	12 / 17	10 / 18	25 / 12	25 / 15	25 / 18	22 / 17	20 / 18	18 / 17	17 / 18	29 / 18	26 / 17	25 / 18	102
	2.80		13 / 13	12 / 18	25 / 10	25 / 13	25 / 15	25 / 18	22 / 18	20 / 18	18 / 18	16 / 18	28 / 18	26 / 18	24 / 18	110
	3.00		13 / 14	12 / 18	25 / 10	25 / 13	25 / 16	24 / 18	20 / 17	19 / 18	18 / 19	29 / 18	28 / 19	24 / 17	22 / 16	118
		16	24	31	39	47	55	63	71	79	87	94	102	110	118	in

**CONTROL**

MINI	
LIGHT	
MEDIUM	
HEAVY	
<b>OUTSIDE SPECIFICATIONS</b>	

1.5" TUBE CAPACITY: - - - - -

**PARAMETERS**





FABRIC DENSITY: 420gsm  
 FABRIC THICKNESS: 0.5mm  
 WEIGHT BAR: D30 Medium Bottom Rail + Ballast = 350grams/m (0.235 lbs/foot)  
 TUBE: 1.5"  
 x / x : POSITION / PRE-TURNS

**SPRING CAPACITY CHART | 350GSM | 1.5" TUBE**

350gsm | 1.5" Tube

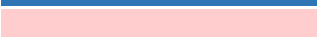
		WIDTH														
m		0.40	0.60	0.80	1.00	1.20	1.40	1.60	1.80	2.00	2.20	2.40	2.60	2.80	3.00	
<b>DROP</b>	0.60	4 / 16	11 / 15	8 / 15	7 / 16	12 / 15	10 / 15	9 / 16	8 / 16	7 / 15	6 / 15	24 / 15	22 / 15	21 / 16	19 / 15	24
	0.80	4 / 16	11 / 15	8 / 15	6 / 15	12 / 16	10 / 16	9 / 16	8 / 16	7 / 16	25 / 15	24 / 16	22 / 16	20 / 15	19 / 16	31
	1.00	4 / 17	11 / 16	8 / 16	6 / 15	11 / 15	10 / 16	9 / 17	7 / 15	7 / 16	25 / 15	23 / 16	21 / 15	20 / 16	19 / 16	39
	1.20	4 / 17	11 / 16	8 / 16	6 / 16	11 / 16	10 / 17	8 / 15	7 / 15	7 / 17	25 / 16	23 / 16	21 / 16	20 / 16	18 / 16	47
	1.40	4 / 18	11 / 17	8 / 17	6 / 16	11 / 16	9 / 16	8 / 16	25 / 13	25 / 15	25 / 17	23 / 17	21 / 16	19 / 16	18 / 16	55
	1.60	4 / 18	10 / 16	8 / 17	13 / 16	11 / 17	9 / 16	8 / 16	25 / 14	25 / 15	24 / 16	22 / 16	21 / 17	19 / 17	18 / 17	63
	1.80	4 / 19	10 / 17	8 / 18	13 / 17	11 / 17	9 / 17	25 / 12	25 / 14	25 / 16	24 / 17	22 / 17	20 / 17	19 / 17	18 / 18	71
	2.00	4 / 20	10 / 17	7 / 16	13 / 17	11 / 18	9 / 17	25 / 13	25 / 15	25 / 17	24 / 18	22 / 18	20 / 17	19 / 18	17 / 17	79
	2.20		10 / 18	13 / 14	13 / 18	11 / 19	9 / 18	25 / 13	25 / 15	25 / 17	23 / 17	21 / 17	20 / 18	18 / 17	17 / 18	87
	2.40		10 / 18	13 / 14	13 / 19	10 / 17	25 / 11	25 / 13	25 / 16	25 / 18	23 / 18	21 / 18	20 / 19	18 / 18	17 / 18	94
	2.60		10 / 19	13 / 15	13 / 19	10 / 18	25 / 12	25 / 14	25 / 16	25 / 18	23 / 19	20 / 18	19 / 18	18 / 19	17 / 19	102
	2.80		10 / 20	13 / 15	12 / 18	25 / 10	25 / 12	25 / 14	25 / 17	25 / 19	23 / 19	20 / 18	19 / 19	18 / 19	29 / 17	110
	3.00		10 / 21	13 / 16	12 / 19	25 / 10	25 / 12	25 / 15	25 / 17	25 / 20	20 / 17	20 / 19	19 / 20	29 / 17	28 / 17	118
		16	24	31	39	47	55	63	71	79	87	94	102	110	118	in

**CONTROL**

MICRO	
SMALL	
LIGHT	
MEDIUM	
HEAVY	
<b>OUTSIDE SPECIFICATIONS</b>	

**PARAMETERS**

FABRIC DENSITY: 350gsm  
 FABRIC THICKNESS: 0.38mm  
 WEIGHT BAR: D30 Medium Bottom Rail + Ballast = 350grams/m (0.235 lbs/foot)  
 TUBE: 1.5"  
 x / x : POSITION / PRE-TURNS





1.5" TUBE CAPACITY: - - - - -

**SPRING CAPACITY CHART | 220GSM | 1.5" TUBE**

220gsm | 1.5" Tube

		WIDTH														
m		0.40	0.60	0.80	1.00	1.20	1.40	1.60	1.80	2.00	2.20	2.40	2.60	2.80	3.00	
<b>DROP</b>	0.60	5 / 18	5 / 25	4 / 27	13 / 25	11 / 26	9 / 25	8 / 26	7 / 26	13 / 24	13 / 26	12 / 27	11 / 27	10 / 26	9 / 26	24
	0.80	5 / 18	5 / 26	4 / 28	13 / 26	11 / 27	9 / 26	8 / 27	13 / 23	13 / 25	12 / 26	11 / 26	10 / 25	10 / 27	9 / 27	31
	1.00	5 / 19	5 / 27	13 / 22	13 / 28	10 / 26	9 / 27	13 / 21	13 / 24	13 / 26	12 / 27	11 / 27	10 / 26	9 / 26	25 / 19	39
	1.20	5 / 19	4 / 23	13 / 23	12 / 27	10 / 27	9 / 28	13 / 22	13 / 25	13 / 27	12 / 28	11 / 28	10 / 28	25 / 18	25 / 20	47
	1.40	5 / 20	4 / 24	13 / 24	12 / 28	10 / 28	13 / 20	13 / 23	13 / 25	13 / 28	11 / 27	10 / 26	25 / 18	25 / 19	25 / 20	55
	1.60	5 / 20	13 / 18	13 / 25	12 / 29	10 / 29	13 / 20	13 / 23	13 / 26	12 / 27	11 / 28	25 / 17	25 / 18	25 / 20	25 / 21	63
	1.80	5 / 21	13 / 19	13 / 26	11 / 28	13 / 18	13 / 21	13 / 24	13 / 28	12 / 28	25 / 16	25 / 17	25 / 19	25 / 20	25 / 22	71
	2.00	4 / 17	13 / 20	13 / 27	11 / 29	13 / 18	13 / 22	13 / 25	13 / 29	11 / 27	25 / 16	25 / 18	25 / 19	25 / 21	25 / 22	79
	2.20	4 / 18	13 / 20	13 / 28	11 / 30	13 / 19	13 / 23	13 / 26	12 / 27	25 / 15	25 / 16	25 / 18	25 / 20	25 / 21	25 / 23	87
	2.40	4 / 18	13 / 21	13 / 29	13 / 16	13 / 20	13 / 23	13 / 27	25 / 13	25 / 15	25 / 17	25 / 19	25 / 20	25 / 22	25 / 24	94
	2.60		13 / 22	13 / 30	13 / 16	13 / 20	13 / 24	11 / 24	25 / 13	25 / 15	25 / 17	25 / 19	25 / 21	25 / 23	25 / 25	102
	2.80		13 / 22	13 / 31	13 / 17	13 / 21	13 / 25	25 / 12	25 / 14	25 / 16	25 / 18	25 / 20	25 / 22	25 / 24	25 / 26	110
	3.00		13 / 23	13 / 32	13 / 17	13 / 22	11 / 22	25 / 12	25 / 14	25 / 16	25 / 18	25 / 20	25 / 23	25 / 25	20 / 21	118
			16	24	31	39	47	55	63	71	79	87	94	102	110	118

**CONTROL**

MICRO	
SMALL	
LIGHT	
MEDIUM	
HEAVY	
<b>OUTSIDE SPECIFICATIONS</b>	

**PARAMETERS**

FABRIC DENSITY: 220gsm  
 FABRIC THICKNESS: 0.55mm  
 WEIGHT BAR: D30 Medium Bottom Rail + Ballast = 350grams/m (0.235 lbs/foot)  
 TUBE: 1.5"  
 x / x : POSITION / PRE-TURNS

**1.5" TUBE CAPACITY** - - - - -

**SPRING CAPACITY CHART | 155GSM | 1.5" TUBE**

155gsm | 1.5" Tube

		WIDTH														
m		0.40	0.60	0.80	1.00	1.20	1.40	1.60	1.80	2.00	2.20	2.40	2.60	2.80	3.00	
<b>DROP</b>	0.60	5 / 16	5 / 23	5 / 30	4 / 30	13 / 27	13 / 31	11 / 31	10 / 32	9 / 32	13 / 24	13 / 26	13 / 28	13 / 30	13 / 32	24
	0.80	5 / 16	5 / 23	4 / 25	13 / 24	13 / 28	13 / 32	11 / 31	10 / 32	9 / 33	13 / 24	13 / 26	13 / 29	13 / 31	13 / 33	31
	1.00	5 / 16	5 / 24	4 / 26	13 / 24	13 / 28	13 / 33	11 / 32	10 / 33	13 / 23	13 / 25	13 / 27	13 / 29	13 / 31	12 / 31	39
	1.20	5 / 16	5 / 24	13 / 20	13 / 24	13 / 29	12 / 31	11 / 33	13 / 21	13 / 23	13 / 25	13 / 28	13 / 30	13 / 32	12 / 32	47
	1.40	5 / 16	4 / 20	13 / 20	13 / 25	13 / 30	12 / 32	11 / 34	13 / 21	13 / 23	13 / 26	13 / 28	13 / 30	13 / 33	11 / 30	55
	1.60	5 / 16	4 / 20	13 / 20	13 / 25	13 / 30	12 / 33	11 / 35	13 / 21	13 / 24	13 / 26	13 / 29	13 / 31	11 / 29	25 / 17	63
	1.80	5 / 16	4 / 20	13 / 20	13 / 26	13 / 31	12 / 34	13 / 19	13 / 22	13 / 24	13 / 27	13 / 29	12 / 29	25 / 16	25 / 17	71
	2.00	5 / 16	13 / 15	13 / 20	13 / 26	13 / 32	12 / 35	13 / 19	13 / 22	13 / 25	13 / 27	12 / 28	25 / 14	25 / 16	25 / 17	79
	2.20	5 / 17	13 / 15	13 / 21	13 / 27	13 / 33	13 / 17	13 / 19	13 / 22	13 / 25	12 / 26	25 / 13	25 / 14	25 / 16	25 / 17	87
	2.40	5 / 17	13 / 15	13 / 21	13 / 27	13 / 33	13 / 17	13 / 20	13 / 23	13 / 26	25 / 12	25 / 13	25 / 15	25 / 16	25 / 17	94
	2.60	4 / 13	13 / 15	13 / 21	13 / 28	13 / 34	13 / 17	13 / 20	13 / 23	12 / 24	25 / 12	25 / 13	25 / 15	25 / 16	25 / 18	102
	2.80	4 / 13	13 / 15	13 / 22	13 / 29	13 / 14	13 / 17	13 / 20	13 / 24	25 / 10	25 / 12	25 / 13	25 / 15	25 / 16	25 / 18	110
3.00	4 / 13	13 / 15	13 / 22	13 / 29	13 / 14	13 / 17	13 / 21	11 / 20	25 / 10	25 / 12	25 / 13	25 / 15	25 / 16	25 / 18	118	
		16	24	31	39	47	55	63	71	79	87	94	102	110	118	in

**CONTROL**

<b>MICRO</b>	
<b>SMALL</b>	
<b>LIGHT</b>	
<b>MEDIUM</b>	
<b>OUTSIDE SPECIFICATIONS</b>	

1.5" TUBE CAPACITY: - - - - -

**PARAMETERS**

FABRIC DENSITY: 155gsm  
 FABRIC THICKNESS: 0.3mm  
 WEIGHT BAR: D30 Medium Bottom Rail + Ballast = 350grams/m (0.235 lbs/foot)  
 TUBE: 1.5"  
 x / x : POSITION / PRE-TURNS

**SPRING CAPACITY CHART | 420GSM | 2" TUBE**

420gsm | 2" Tube

		WIDTH														
m		0.40	0.60	0.80	1.00	1.20	1.40	1.60	1.80	2.00	2.20	2.40	2.60	2.80	3.00	
<b>DROP</b>	0.60	5 / 9	11 / 11	8 / 11	6 / 11	22 / 11	19 / 11	16 / 11	27 / 11	24 / 11	22 / 11	20 / 11	19 / 11	17 / 11	16 / 11	24
	0.80	5 / 9	11 / 11	8 / 11	6 / 11	22 / 11	19 / 11	16 / 11	27 / 11	24 / 11	22 / 11	20 / 11	19 / 11	17 / 11	16 / 11	31
	1.00	5 / 9	11 / 12	8 / 12	6 / 11	21 / 11	18 / 11	16 / 11	27 / 11	24 / 11	22 / 11	20 / 11	18 / 11	17 / 11	16 / 11	39
	1.20	5 / 9	11 / 12	8 / 12	6 / 11	21 / 11	18 / 11	16 / 12	26 / 11	24 / 12	22 / 12	20 / 12	18 / 11	17 / 12	15 / 11	47
	1.40	5 / 9	10 / 11	8 / 12	6 / 12	21 / 12	18 / 12	29 / 11	26 / 12	24 / 12	21 / 11	20 / 12	18 / 12	17 / 12	15 / 11	55
	1.60	5 / 9	10 / 12	8 / 12	25 / 12	21 / 12	18 / 12	29 / 12	26 / 12	23 / 12	21 / 12	19 / 12	18 / 12	16 / 12	15 / 12	63
	1.80	5 / 9	10 / 12	7 / 11	25 / 12	21 / 12	18 / 12	29 / 12	26 / 12	23 / 12	20 / 12	19 / 12	17 / 12	16 / 12	15 / 12	71
	2.00	5 / 9	10 / 12	7 / 12	25 / 13	20 / 12	17 / 12	28 / 12	25 / 12	22 / 12	20 / 12	19 / 12	17 / 12	16 / 12	15 / 12	79
	2.20	5 / 9	10 / 13	7 / 12	24 / 12	20 / 12	17 / 12	28 / 12	25 / 12	22 / 12	20 / 12	19 / 13	17 / 12	16 / 13	15 / 13	87
	2.40	5 / 9	10 / 13	7 / 12	24 / 13	20 / 13	17 / 13	28 / 13	25 / 13	22 / 13	20 / 13	19 / 13	17 / 13	16 / 13	15 / 13	94
	2.60	5 / 9	10 / 13		24 / 13	20 / 13	17 / 13	28 / 13	24 / 13	22 / 13	20 / 13	18 / 13	17 / 13	15 / 12	15 / 13	102
	2.80		10 / 14		24 / 14	20 / 14	17 / 14	28 / 13	24 / 13	22 / 13	20 / 13	18 / 13	17 / 13	15 / 13		110
	3.00		9 / 13		23 / 13	19 / 13	17 / 14	27 / 13	24 / 13	22 / 14	20 / 14	18 / 13	17 / 14			118
			16	24	31	39	47	55	63	71	79	87	94	102	110	118

**CONTROL**

MINI	
LIGHT	
MEDIUM	
HEAVY	
<b>OUTSIDE SPECIFICATIONS</b>	

**PARAMETERS**

FABRIC DENSITY: 420gsm  
 FABRIC THICKNESS: 0.5mm  
 WEIGHT BAR: D30 Medium Bottom Rail + Ballast = 350grams/m (0.235 lbs/foot)  
 TUBE: 2"  
 x / x : POSITION / PRE-TURNS

**SPRING CAPACITY CHART | 350GSM | 2" TUBE**

350gsm | 2" Tube

		WIDTH														
m		0.40	0.60	0.80	1.00	1.20	1.40	1.60	1.80	2.00	2.20	2.40	2.60	2.80	3.00	
<b>DROP</b>	0.60	5 / 8	13 / 12	10 / 12	8 / 12	6 / 12	23 / 12	20 / 12	18 / 12	16 / 12	27 / 12	25 / 12	23 / 12	21 / 12	20 / 12	24
	0.80	5 / 8	13 / 12	10 / 12	8 / 13	6 / 12	23 / 12	20 / 12	18 / 13	16 / 12	27 / 12	24 / 12	22 / 12	21 / 12	20 / 12	31
	1.00	5 / 8	13 / 12	10 / 13	8 / 13	6 / 12	22 / 12	20 / 13	17 / 12	29 / 12	26 / 12	24 / 12	22 / 12	20 / 12	19 / 12	39
	1.20	5 / 8	13 / 13	9 / 12	7 / 12	6 / 12	22 / 12	19 / 12	17 / 12	29 / 12	26 / 12	24 / 12	22 / 12	20 / 12	19 / 12	47
	1.40	5 / 8	13 / 13	9 / 12	7 / 12	6 / 12	22 / 13	19 / 13	17 / 13	29 / 13	26 / 13	24 / 13	22 / 13	20 / 12	19 / 13	55
	1.60	5 / 8	13 / 13	9 / 12	7 / 12	25 / 13	22 / 13	19 / 13	17 / 13	28 / 13	26 / 13	24 / 13	22 / 13	20 / 13	19 / 13	63
	1.80	5 / 8	13 / 13	9 / 13	7 / 12	25 / 13	22 / 13	19 / 13	17 / 13	28 / 13	26 / 13	24 / 13	22 / 13	20 / 13	19 / 13	71
	2.00	5 / 8	13 / 14	9 / 13	7 / 13	25 / 13	21 / 13	19 / 13	17 / 13	28 / 13	26 / 13	23 / 13	22 / 13	20 / 13	19 / 13	79
	2.20	5 / 8	12 / 13	9 / 13	7 / 13	25 / 13	21 / 13	19 / 14	16 / 13	28 / 13	25 / 13	23 / 13	21 / 13	20 / 13	18 / 13	87
	2.40	5 / 8	12 / 13	9 / 13	25 / 11	25 / 14	21 / 13	18 / 13	16 / 13	28 / 14	25 / 13	23 / 14	21 / 13	20 / 14	18 / 13	94
	2.60	5 / 8	12 / 13	9 / 14	25 / 11	25 / 14	21 / 14	18 / 14	16 / 14	28 / 14	25 / 14	22 / 13	21 / 14	19 / 13	18 / 14	102
	2.80	5 / 8	12 / 14	9 / 14	25 / 12	24 / 14	21 / 14	18 / 14	16 / 14	27 / 14	24 / 13	22 / 13	20 / 13	19 / 14	18 / 14	110
	3.00		12 / 14	9 / 15	25 / 12	24 / 14	21 / 15	18 / 14	16 / 14	27 / 14	24 / 14	22 / 14	20 / 14	19 / 14	18 / 14	118
			16	24	31	39	47	55	63	71	79	87	94	102	110	118

**CONTROL**

<b>MINI</b>	
<b>LIGHT</b>	
<b>MEDIUM</b>	
<b>HEAVY</b>	
<b>OUTSIDE SPECIFICATIONS</b>	

**PARAMETERS**

FABRIC DENSITY: 350gsm  
 FABRIC THICKNESS: 0.38mm  
 WEIGHT BAR: D30 Medium Bottom Rail + Ballast = 350grams/m (0.235 lbs/foot)  
 TUBE: 2"  
 x / x : POSITION / PRE-TURNS

**SPRING CAPACITY CHART | 220GSM | 2" TUBE**

220gsm | 2" Tube

		WIDTH														
m		0.40	0.60	0.80	1.00	1.20	1.40	1.60	1.80	2.00	2.20	2.40	2.60	2.80	3.00	
<b>DROP</b>	0.60	4 / 19	11 / 18	8 / 18	6 / 17	12 / 18	10 / 18	9 / 19	8 / 19	7 / 18	25 / 18	24 / 18	22 / 18	20 / 18	19 / 18	24
	0.80	4 / 19	11 / 18	8 / 18	6 / 18	11 / 18	10 / 19	9 / 19	7 / 17	7 / 19	25 / 18	23 / 18	21 / 18	20 / 18	18 / 18	31
	1.00	4 / 20	11 / 19	8 / 19	6 / 18	11 / 18	10 / 19	8 / 18	7 / 18	7 / 19	25 / 18	23 / 18	21 / 18	20 / 19	18 / 18	39
	1.20	4 / 20	11 / 19	8 / 19	6 / 18	11 / 18	9 / 18	8 / 18	7 / 18	25 / 17	25 / 19	23 / 19	21 / 19	19 / 18	18 / 19	47
	1.40	4 / 21	10 / 18	8 / 20	13 / 18	11 / 19	9 / 18	8 / 19	25 / 16	25 / 18	24 / 19	22 / 19	21 / 19	19 / 19	18 / 19	55
	1.60	4 / 21	10 / 19	8 / 20	13 / 19	11 / 19	9 / 19	8 / 19	25 / 16	25 / 18	24 / 19	22 / 19	20 / 19	19 / 19	17 / 19	63
	1.80	4 / 22	10 / 19	7 / 18	13 / 19	11 / 20	9 / 19	8 / 20	25 / 17	25 / 19	24 / 20	22 / 20	20 / 19	19 / 20	17 / 19	71
	2.00	4 / 23	10 / 20	7 / 19	13 / 20	11 / 20	9 / 20	25 / 15	25 / 17	25 / 19	23 / 19	21 / 19	20 / 20	18 / 19	17 / 20	79
	2.20		10 / 20	13 / 16	13 / 20	10 / 19	9 / 20	25 / 15	25 / 17	25 / 20	23 / 20	21 / 20	20 / 20	18 / 20	17 / 20	87
	2.40		10 / 21	13 / 17	13 / 21	10 / 20	9 / 21	25 / 16	25 / 18	25 / 20	23 / 20	21 / 20	19 / 20	18 / 20	17 / 21	94
	2.60		10 / 21	13 / 17	12 / 20	10 / 20	25 / 14	25 / 16	25 / 18	25 / 21	23 / 21	20 / 20	19 / 20	18 / 21	16 / 20	102
	2.80	5 / 6	13 / 12	13 / 17	12 / 20	10 / 21	25 / 14	25 / 16	25 / 19	25 / 21	22 / 21	20 / 20	19 / 21	17 / 20	16 / 21	110
3.00	5 / 6	13 / 13	13 / 18	12 / 21	25 / 12	25 / 14	25 / 17	25 / 19	24 / 21	20 / 19	20 / 21	19 / 22	17 / 21	29 / 20	118	
		16	24	31	39	47	55	63	71	79	87	94	102	110	118	in

**CONTROL**

MICRO	
MINI	
SMALL	
LIGHT	
MEDIUM	
HEAVY	
<b>OUTSIDE SPECIFICATIONS</b>	

**PARAMETERS**

FABRIC DENSITY: 220gsm  
 FABRIC THICKNESS: 0.55mm  
 WEIGHT BAR: D30 Medium Bottom Rail + Ballast = 350grams/m (0.235 lbs/foot)  
 TUBE: 2"  
 x / x : POSITION / PRE-TURNS

**SPRING CAPACITY CHART | 155GSM | 2" TUBE**

155gsm | 2" Tube

		WIDTH														
m		0.40	0.60	0.80	1.00	1.20	1.40	1.60	1.80	2.00	2.20	2.40	2.60	2.80	3.00	
<b>DROP</b>	0.60	5 / 21	4 / 24	12 / 23	9 / 22	8 / 23	6 / 21	12 / 22	11 / 22	10 / 23	9 / 23	8 / 22	7 / 21	25 / 20	25 / 21	24
	0.80	5 / 21	4 / 25	12 / 23	9 / 22	7 / 21	6 / 22	12 / 22	11 / 23	10 / 23	9 / 23	8 / 22	25 / 19	25 / 20	25 / 21	31
	1.00	5 / 21	4 / 25	11 / 22	9 / 23	7 / 22	13 / 21	12 / 22	11 / 23	9 / 21	9 / 23	8 / 23	25 / 19	25 / 20	25 / 22	39
	1.20	5 / 21	4 / 26	11 / 22	9 / 23	7 / 22	13 / 21	12 / 23	11 / 23	9 / 22	9 / 24	25 / 18	25 / 19	25 / 21	25 / 22	47
	1.40	5 / 22	4 / 26	11 / 22	9 / 23	7 / 22	13 / 22	12 / 23	11 / 24	9 / 22	9 / 24	25 / 18	25 / 19	25 / 21	25 / 22	55
	1.60	5 / 22	13 / 20	11 / 23	9 / 24	13 / 19	13 / 22	12 / 23	10 / 22	9 / 22	25 / 17	25 / 18	25 / 20	25 / 21	25 / 23	63
	1.80	5 / 22	13 / 20	11 / 23	9 / 24	13 / 19	13 / 22	12 / 24	10 / 22	9 / 23	25 / 17	25 / 18	25 / 20	25 / 21	25 / 23	71
	2.00	5 / 23	13 / 21	11 / 23	9 / 24	13 / 19	13 / 23	12 / 24	10 / 23	25 / 15	25 / 17	25 / 18	25 / 20	25 / 22	25 / 23	79
	2.20	4 / 18	13 / 21	11 / 24	9 / 25	13 / 20	13 / 23	11 / 23	10 / 23	25 / 15	25 / 17	25 / 19	25 / 20	25 / 22	25 / 24	87
	2.40	4 / 19	13 / 21	11 / 24	13 / 16	13 / 20	13 / 23	11 / 23	25 / 14	25 / 15	25 / 17	25 / 19	25 / 21	25 / 22	25 / 24	94
	2.60	4 / 19	13 / 21	11 / 25	13 / 16	13 / 20	13 / 24	11 / 23	25 / 14	25 / 16	25 / 17	25 / 19	25 / 21	25 / 23	25 / 25	102
	2.80		13 / 22	11 / 25	13 / 16	13 / 20	13 / 24	11 / 24	25 / 14	25 / 16	25 / 17	25 / 19	25 / 21	25 / 23	24 / 24	110
3.00		13 / 22	11 / 26	13 / 17	13 / 21	13 / 25	25 / 12	25 / 14	25 / 16	25 / 18	25 / 20	25 / 22	25 / 23	24 / 24	118	
		16	24	31	39	47	55	63	71	79	87	94	102	110	118	in

**CONTROL**

<b>MICRO</b>	
<b>SMALL</b>	
<b>LIGHT</b>	
<b>MEDIUM</b>	
<b>OUTSIDE SPECIFICATIONS</b>	

**PARAMETERS**

FABRIC DENSITY: 155gsm  
 FABRIC THICKNESS: 0.3mm  
 WEIGHT BAR: D30 Medium Bottom Rail + Ballast = 350grams/m (0.235 lbs/foot)  
 TUBE: 2"  
 x / x : POSITION / PRE-TURNS

## OPEN SYSTEM

### Open Roll Brackets

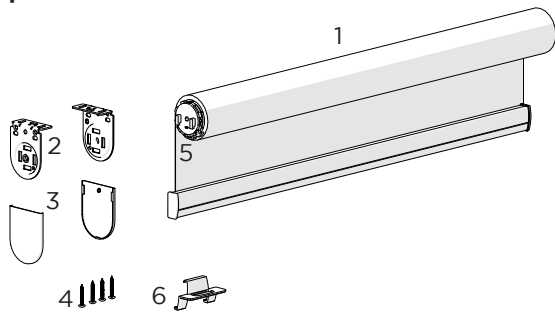

1. Shade Assembly x 1
2. Bracket Covers Set x 1:
3. Mounting Bracket Set x 1
4. Screws x 4
5. Tension Lock
6. D30 handle (loose)

**NOTE**

The Tension Lock must be removed before the shade is operated.

## CASSETTE SYSTEM

### Cassette 100

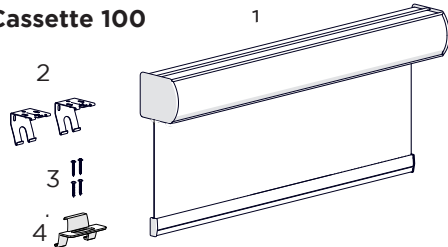

1. Shade Assembly
2. Mounting Brackets (as required)
3. Appropriate Fasteners (as required)
4. D30 handle (loose)

**NOTE**

The clip must be removed after installation.

### Cassette 110

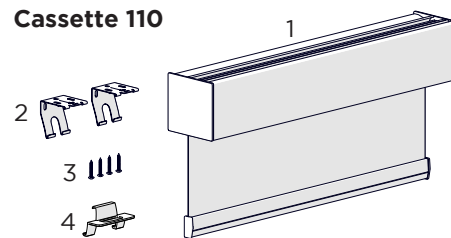

1. Shade Assembly
2. Mounting Brackets (as required)
3. Appropriate Screws (as required)
4. D30 handle (loose)

**NOTE**

The clip must be removed before the shade is operated.