

ZIPSCREEN SKYLIGHT

The Zipscreen Skylight system offers a refined solution for light block out in any horizontal or sloped windows. Using secure zip locking channels, the system achieves perfect tension of fabric in all directions during operation and while stationary. Electronically operated, it's the ultimate system for energy saving throughout buildings, adaptable for both commercial and domestic applications.

AESTHETICAL FEATURES

- Contemporary square architectural design.
- Custom colour matching achievable
- No visible tape for Zipscreen Skylight

PRODUCTION / ASSEMBLY FEATURES

- Removable front covers for ease of maintenance and assembly.
- Uses S60 components for large applications.
- Zip reducers designed to accommodate zip build up preventing fabric ripples.

FUNCTIONAL BENEFITS

- Further enhances energy conservation compared to a standard roller blind.
- Versatile system for horizontal or angled applications.

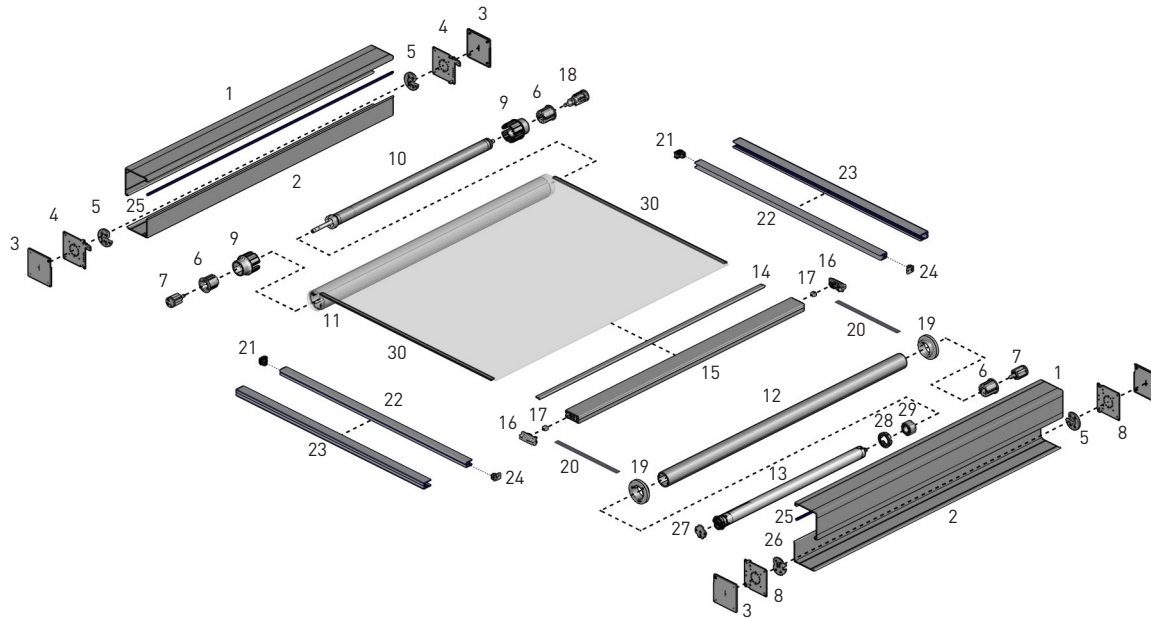

SYSTEM OPTIONS

BOX100
(Alternative Cassette)

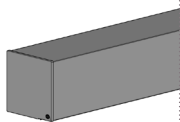

CONTROL

MOTORIZED + SPRING



COLOUR RANGE



mill
000

SYSTEM INDEX

1	Box 120 - TOP & BACK SB01-1340-xxxLLL
2	Box 120 - Cover SB01-1326-xxxLLL
3	Box 120 'SH33' End Plate Cove SB02-1220-xxx020
4	Box 120 - Universal End Plate Set - With Ears SB02-1201-025020
5	RB10 Idler Head Adapter RB10-6400-050001
6	RB10 Tube Adapter RB10-6000-xxx060
7	RB10 Bearing Idler RB10-6200-xxx001
8	Box 120 - Universal End Plate Set - With Ears SB02-1201-025020
9	Zip Tube Reducer Long SB11-0815-050580
10	RB10 Booster Extra Heavy (LH) RB10-6040-xxx051
11	SYS60 80HD Aluminium Tube • O.D 80.0mm RB91-0280-000LLL
12	SYS60 60STD Aluminium Tube • O.D 60.0mm RB91-0260-xxxLLL
13	FT Motor See Catalog
14	7.2mm Spline with 15mm Tail SB91-0408-xxx015
15	F72 HD Weight Bar RE15-0112-xxxLLL
16	F72 Multi-bar End Caps RE15-0512-xxx000
17	F72 Multi-bar Cord Guide Set RE15-0532-xxx000
18	RB10 Pre-Tension Idler RB10-6220-050001
19	SKYLIGHT Tape Spool - 9mm Tape + Fixing Screw SYS60 SS48-1061-xxx090
20	Lift Tape, Outdoor SS95-6038-050500
21	Skylight Zipscreen Inner Rail End Cap + Screw SB05-1611-xxx001
22	ZIPSCREEN - Zip Inner Rail SB04-0701-xxxLLL
23	ZIPSCREEN - 'U' Mounting Rail SB04-0702-xxxLLL
24	Zipscreen Inner Rail Funnel & Stop Set SB05-1411-050001
25	Fabric Brush T Slot Fit SB91-0011-xxxLLL
26	Motor Adapter See Catalog
27	Motor Head Plate See Catalog
28	Crown Wheel S60 See Catalog
29	Drive Wheel S60 See Catalog
30	ZIP No.6 GAUGE SH91-0135-050200

xxx= colour

SPECIFICATIONS

MAX ROLL

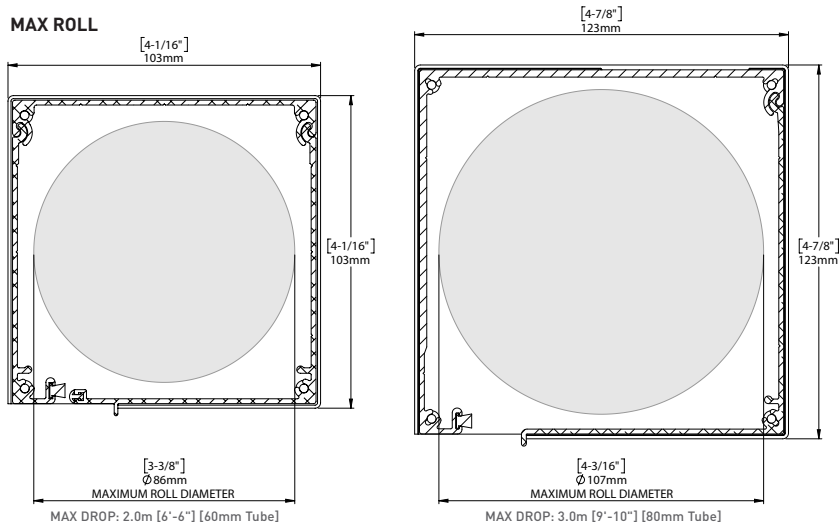

ARCHITECTURAL VIEWS

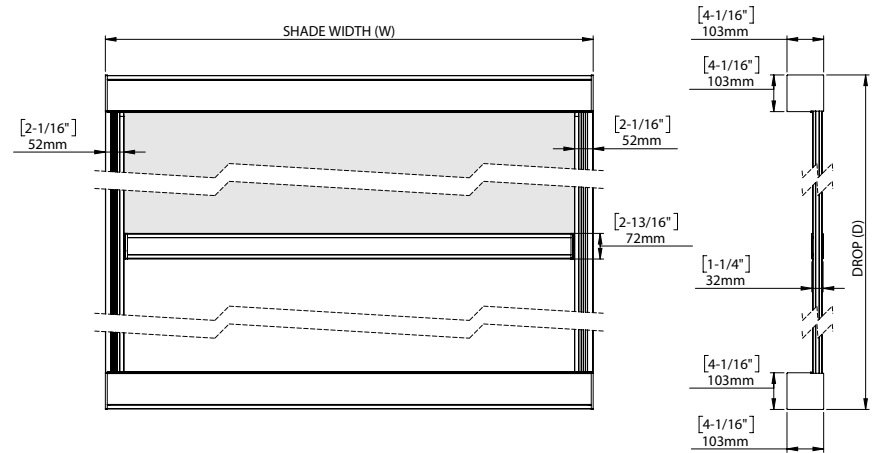

SYSTEM CAPACITY

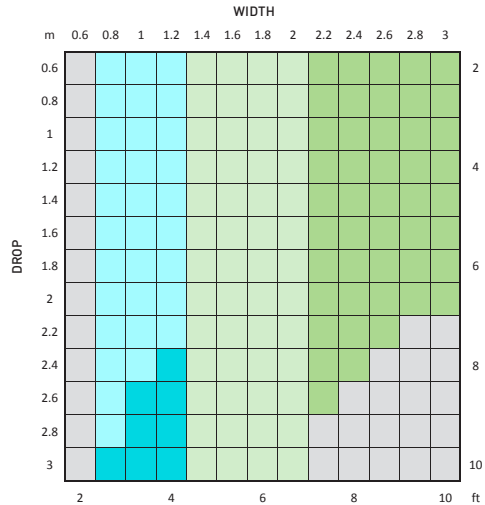

Fabric: 420gsm (12.4oz/yd²) Weight/Hem Bar: F72 (Zipscreen)

CONTROL	TUBE
SHORT	Zipscreen
EXTRA HEAVY	Zipscreen

Short Booster - Minimum Shade Width = 0.8m (3ft) | EXTRA Heavy Booster - Minimum Shade Width = 1.25m (4ft)

TUBE SPECS

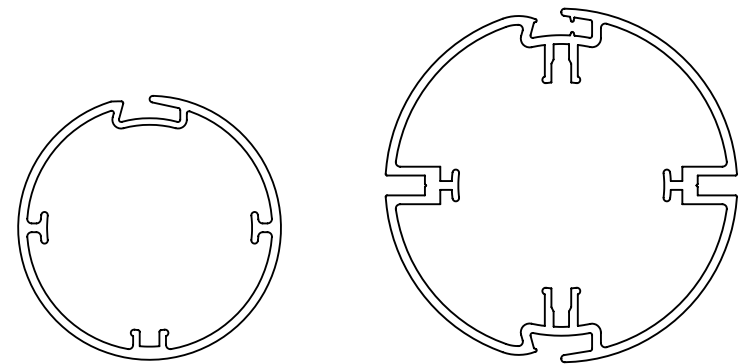

S60 | 60 STANDARD TUBE

Code: RB91-0260-000580
 OD: 60mm (2.36")
 Length: 5.8m (19 ft)

S60 | 80 HEAVY DUTY TUBE

Code: RB91-0280-000480
 RB91-0280-000580
 OD: 80mm (3.15")
 Length: 4.8m (15.7 ft), 5.8m (19 ft)