



AWNING SYSTEMS

PRODUCT SPECIFICATIONS

v1.9 | August 2024

CONTENTS

PIUMA	3
YUKI	4
MOTOR SPECIFICATIONS	5
DRAWINGS	6

DISCLAIMER

DISCLAIMER

Rollease Acmeda has used reasonable care in preparing the information included in this document, but makes no representations or warranties as to the completeness or accuracy of the information. Information is supplied upon the condition that the persons receiving the information will make their own determination as to its suitability for their purposes prior to use. Rollease Acmeda assumes no liability whatsoever for any damages incurred by you resulting from errors in or omissions from the information included herein. Rollease Acmeda reserves the right to make changes without further notice to any products to improve reliability, function or design.

COPYRIGHT

COPYRIGHT © ROLLEASE ACMEDA

All rights are reserved. No part of this document may be reproduced or utilised in any means, by any means, electronic or mechanical including photocopying, recordings, or by any information storage or retrieval system, without the express permission from Rollease Acmeda.

FOLDING ARM AWNING SYSTEM

PIUMA

UPGRADE OPTIONS

PROTECTION HOOD

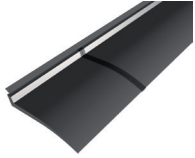

CONTROL OPTIONS

MOTOR

CRANK GEAR (2 ARMS)



NO. OF BRACKETS

PROJECTION (cm)	WIDTH (cm)						
	251-300	301-360	361-410	411-480	481-540	541-600	601-700
	2 ARMS						3 ARMS
204	2	2	3	3	3	4	5
254	-	2	3	3	4	4	5
304	-	-	3	3	4	4	5
SUPPORT CONVEYOR QTY			0	0	0	1	1

WEIGHT (kg)

PROJECTION (cm)	WIDTH (cm)					
	200	300	400	500	600	700
	2 ARMS					3 ARMS
204	27	34	40	47	53	59
254	29	36	42	49	56	61
304	31	38	44	51	58	63

MINIMUM WIDTH

PROJECTION (cm)	WIDTH (cm)	
	No. of arms	
	2	3
204	223	346
254	273	421
304	232	496

ARM PROJECTION AND INCLINATION

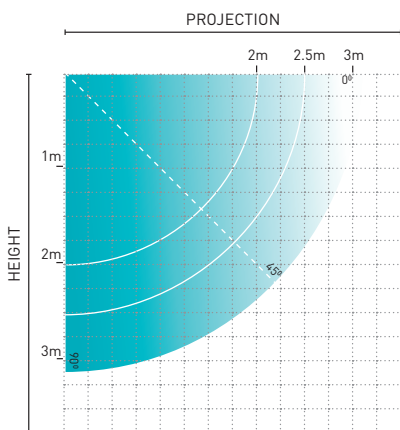

AWNING SIZES

WALL / TOP FIX

0° INCLINATION

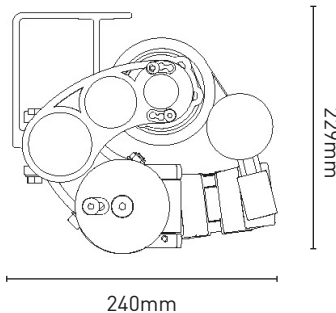

90° INCLINATION

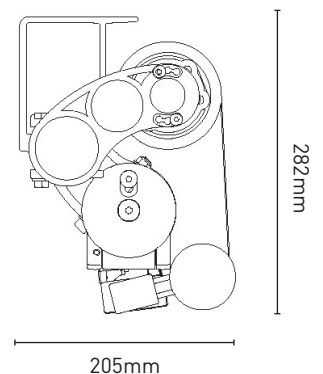

SYSTEM CAPACITY

Max Width	7m
Max projection	3.04m
Wind Resistance	Class 2, EN 13561 (600 cm x 265 cm) (37 km/h)

FOLDING ARM AWNING SYSTEM

YUKI

CONTROL OPTIONS

MOTOR CRANK GEAR



WEIGHT (kg)

PROJECTION (cm)	WIDTH (cm)			
	200	300	400	500
	2 ARMS			
209	31	39	47	55
259	32	40	49	56
309	33	41	51	58

MINIMUM WIDTH

PROJECTION (cm)	WIDTH (cm)
	No. of arms
	2
209	222
259	272
309	322

ARM PROJECTION AND INCLINATION

WALL FIX

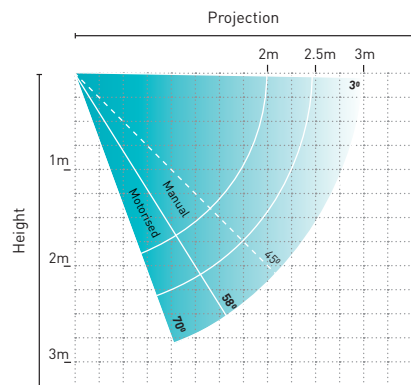

TOP FIX

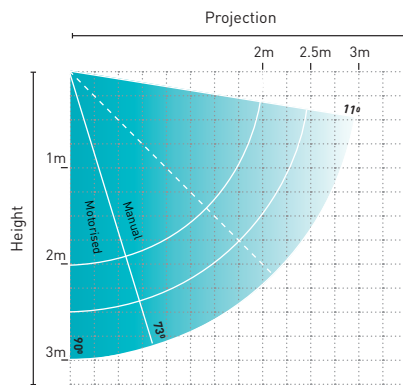

AWNING SIZES

WALL

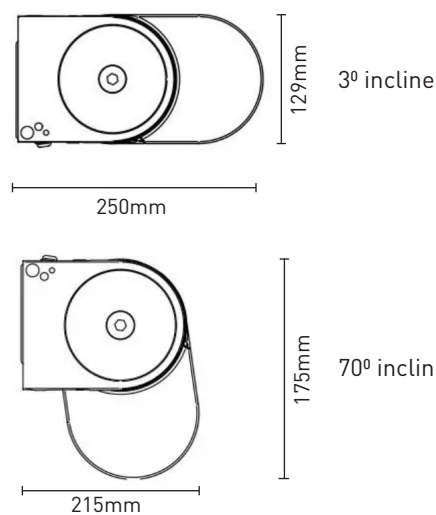

TOP FIX

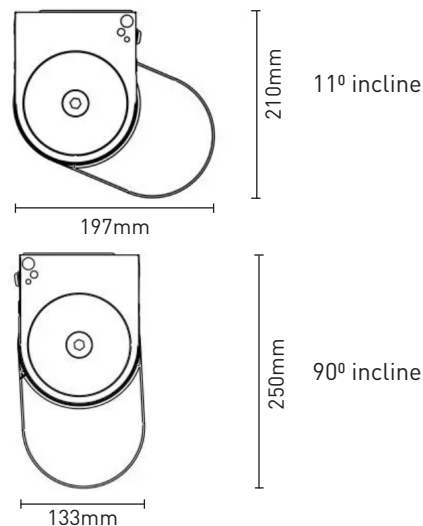

SYSTEM CAPACITY

Max Width	5m
Max projection	3.09m
Wind Resistance	Class 2, EN 13561 (480 cm x 265 cm) (37 km/h)

MOTOR SPECIFICATIONS

PIUMA

PROJECTION (cm)		WIDTH (cm)							
		2 ARMS						3 ARMS	
		240	300	360	410	480	540	600	650
204	30 Nm							50 Nm	
254									
304									

YUKI

PROJECTION (cm)		WIDTH (cm)			
		2 ARMS			
		222	300	400	500
209	30 Nm				
259					
309					

DRAWINGS

PIUMA

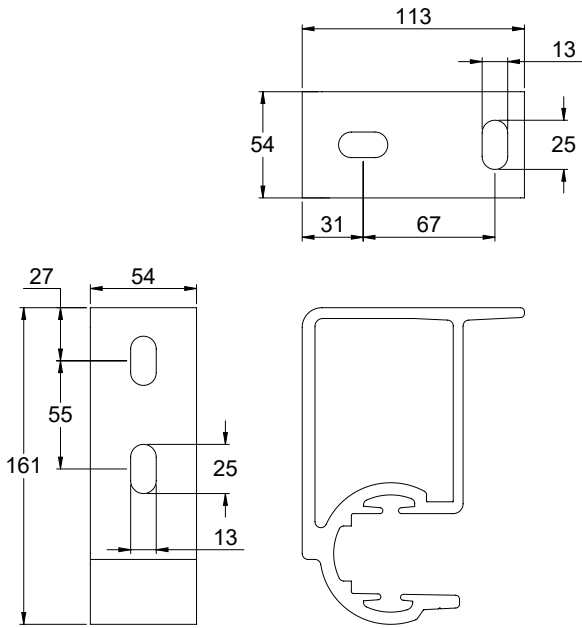

YUKI

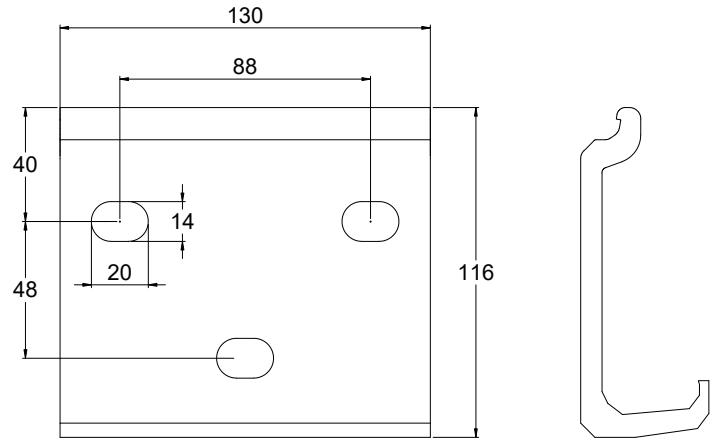

AWNING PROTECTION HOOD

Maximum bracket spacing every 2m.

