

AUTOMATE C MOTORIZED CURTAIN SYSTEM

Our Automate C motor and curtain track solution offers a complete motorised curtain solution. Featuring a smart SOFT open and close function with auto adjusting speed limits. This impressive motor is operated by our Automate remote controls, is quiet for optimal acoustic comfort and comes complete with a 5 year warranty.

AESTHETICAL FEATURES

- Slim profile curtain track.
- Track Joiner allowing multiple tracks to be seamlessly linked.
- S-Fold curtain compatible parts for snap tape.

FUNCTIONAL BENEFITS

- Centre and one way draw for straight and curved applications.
- Soft open and close auto adjusting speed limits.
- Manual override function to open/close with one light touch.
- Quiet motor.
- 50kg max lifting capacity.
- Built in receiver for radio control.
- ARC Bi-directional communication.
- Remote or smart phone control.

INSTALLATION/ ASSEMBLY FEATURES

- Easy automatic limit setting.
- Top Fix and Wall Fix installation.
- Double bracket for a two wall mounted curtains configuration.
- Dual day/night curtain functionality

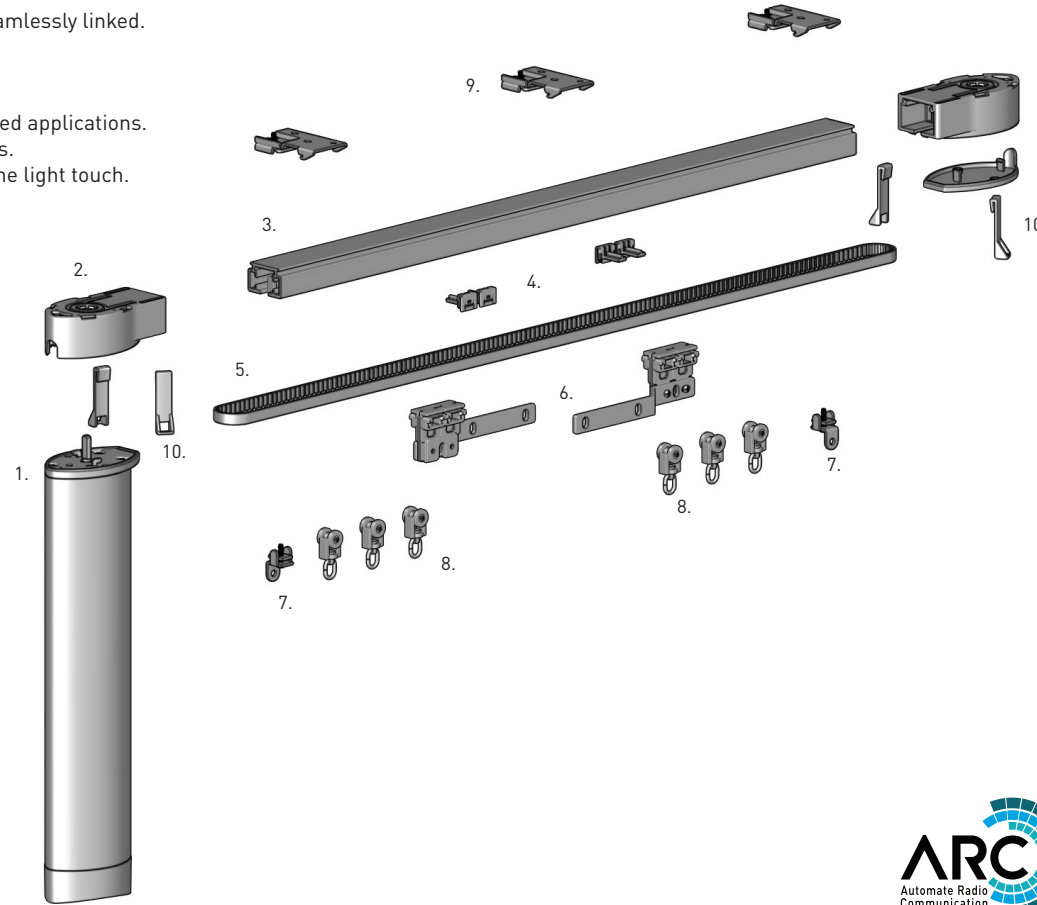

SYSTEM INDEX

1.	AUTOMATE C ARC Drape Motor
(a)	MT01-2101-xxx001 (AU)
(b)	MTACRFDR-50KG (US)
(c)	MTACRFDR-50KGLC (US)
2.	Drive Unit Kit for ARC Motor
	CU21-0211-062001
3.	Curtain Track
	CU21-0101-062550
4.	Belt Fastening Button
	CU21-0301-158001
5.	Rubber Belt
	MTDR-BELT
6.	Master Carrier
	CU21-0401-010020
7.	Stopper
	CU21-0401-010010
8.	Runners
	CU21-0401-062001
9.	Ceiling Bracket
	CU21-0501-062001
10.	End Hook
	CU21-0201-062003

CONTROL OPTIONS



ALTERNATE OPTION

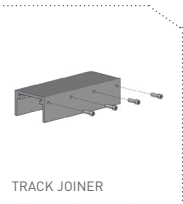

BRACKET OPTIONS

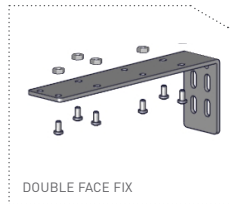
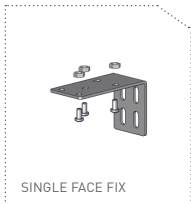

S-FOLD OPTION

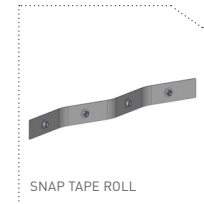
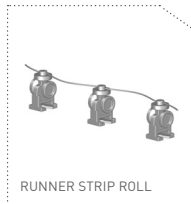

COLOUR RANGE

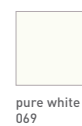

SPECIFICATIONS

DEDUCTION

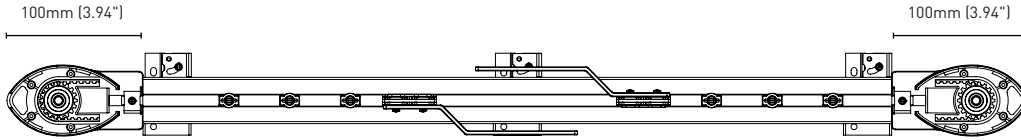

CONTROL SIDE	DRIVE SIDE	OVERALL DEDUCTION
75mm [2.95"]	75mm [2.95"]	150mm [5.91"]

TRACK PROFILE & DIMENSIONS

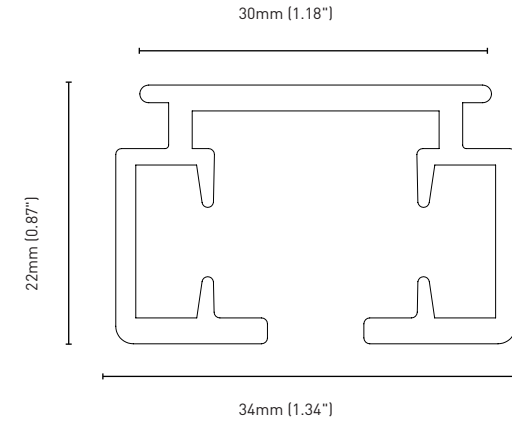

DRAPE MOTOR SPECIFICATIONS			
Code	MT01-2101-xxx001	MTACRFDR-50KG	MTACRFDR-50KGLC
Region	AU/EU	US	US
Power Cable Length	2500mm [8.2ft]	3000mm [9.84ft]	6000mm [19.69ft]
Supply Voltage	100-240V; 50Hz	100-120V; 60Hz	
Capacity	1.2Nm @ 14cm/s		
Running Time	12 min		
Max Current	0.2A	0.3A	
Consumption	48W	36W	
Protection class	IP40		
Frequency	433.92 MHz		
Sound Level	52dB		
Weight	1.5 Kg [0.88 lbs]		
RF Modulation	FSK		
Limit Switch Type	Electronic		
Temp Working Range	0 °C to 60 °C		
Insulation Class	II		

STRAIGHT TRACK

ONE WAY



CENTRE CLOSE

