

AUTOMATE VERSA MOTORISED CURTAIN SYSTEM

Our Automate Versa motor and curtain track hardware offers a complete motorised curtain solution. This versatile motor easily connects to two different power sources – a rechargeable lithium-ion battery or an AC power module, providing greater flexibility at installation. Inverted mounting also offers a continuous powered solution hidden within ceiling pockets for a premium aesthetic.

AESTHETICAL FEATURES

- Slim profile curtain track & motor.
- Track Joiner allowing multiple tracks to be seamlessly linked.
- S-Fold curtain compatible parts for snap tape.

FUNCTIONAL BENEFITS

- Inverted mounting option for ceiling pocket installations.
- Connects to two different power sources – a rechargeable lithium-ion battery or an AC power module.
- Centre and one way draw for straight applications.
- Soft open and close auto adjusting speed limits.
- Manual override function to open/close with one light touch.
- Quiet motor.
- 50kg max operating capacity.

INSTALLATION/ ASSEMBLY FEATURES

- Easy automatic limit setting.
- Top and Wall Fix installations.
- Double bracket option for sheer and blackout application.

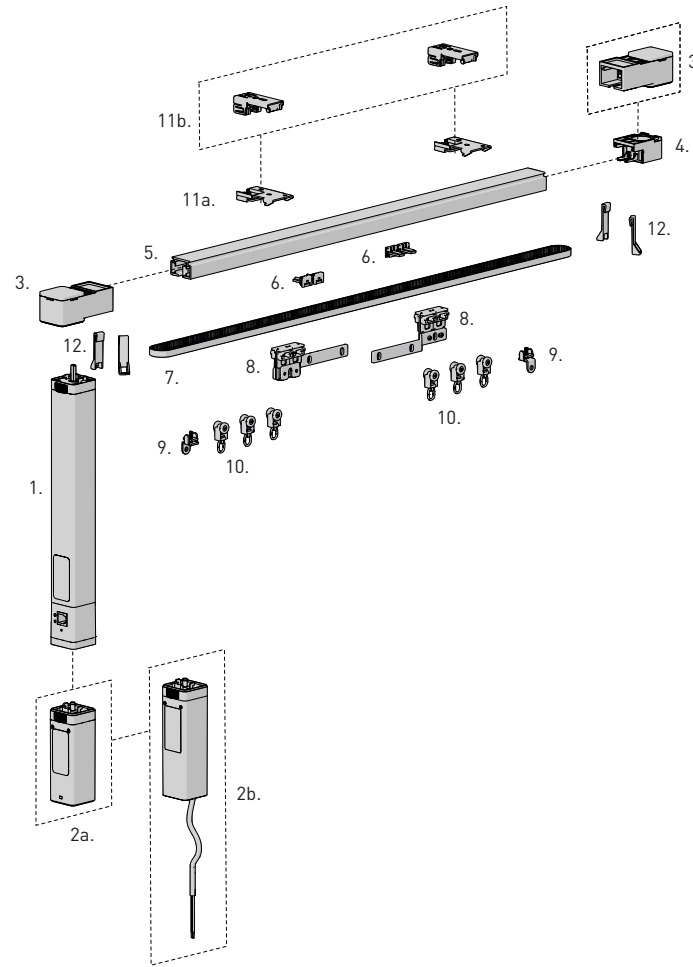

SYSTEM INDEX

1.	AUTOMATE Versa Drapery Motor MT01-2101-069002
2a.	AUTOMATE Drapery Battery Module MT03-0305-069004
2b.	AUTOMATE Versa Module 2.5M Cord (240V) MT03-0305-069010
3.	Versa Motor End "S" Track Pulley MT03-0401-xxx004
4.	AUTOMATE Return Pulley "S" Track MT03-0401-069013
5.	Curtain Track CU21-0101-xxx550
6.	Belt Fastening Button CU21-0301-158001
7.	Rubber Belt CU21-0301-158000
8.	Master Carrier CU21-0401-010020
9.	Stopper CU21-0401-010010
10.	Runners CU21-0401-062001
11.	Ceiling Bracket
a.	CU21-0501-xxx001
b.	MT03-0401-069012
12.	End Hook CU21-0201-xxx003



OPTION

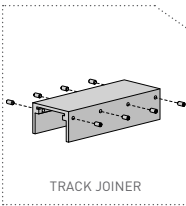

BRACKET OPTIONS

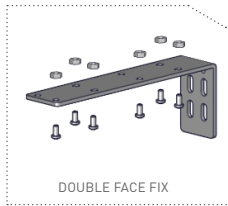
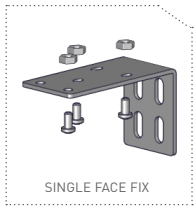

S-FOLD OPTION

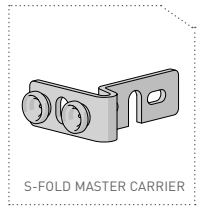

COLOUR RANGE

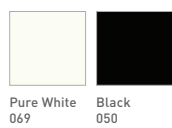

CONTROL OPTIONS



SPECIFICATIONS

DEDUCTION

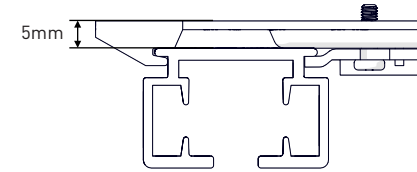
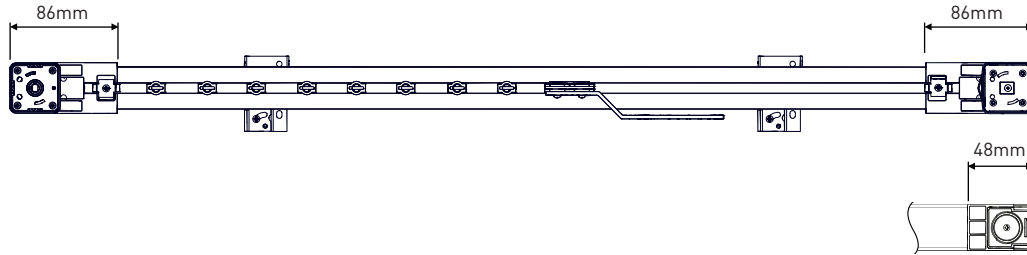

TRACK PROFILE & DIMENSIONS

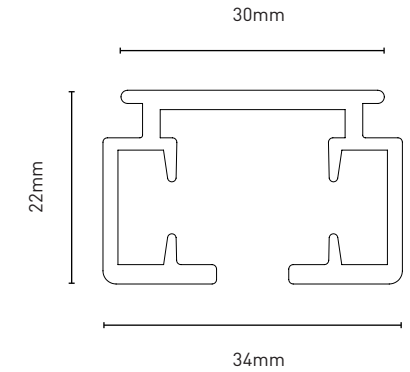

TRACK DEDUCTION				
CURTAIN TYPE	PULLEY TYPES	DRIVE SIDE	RETURN SIDE	OVERALL DEDUCTION
CENTRE OPEN	DRIVE + DRIVE	59mm	59mm	118mm
ONE WAY	DRIVE + RETURN	59mm	33mm	92mm

DRAPE MOTOR SPECIFICATIONS	
Region	AU/EU/UK
Power Cable Length	2500mm
Voltage Input	100 – 240V 50Hz
Capacity	1.2 Nm @ 120 RPM / 14 cm/s
Running Time	12 min
Max Current	1.3 A
Consumption	20 W
Protection class	IP40
Frequency	433.92 MHz
Sound Level	44 dB
Weight	0.83 Kg (Motor Only)
RF Modulation	FSK
Limit Switch Type	Electronic
Temp Working Range	0 °C to 60 °C
Insulation Class	II

STRAIGHT TRACK

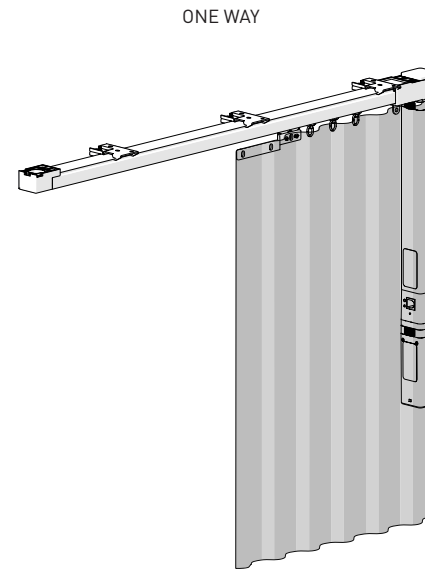

CENTRE CLOSE [S-Fold]

