

REVISION RECORD				
SYM	DESCRIPTION	BY	DATE	CHK

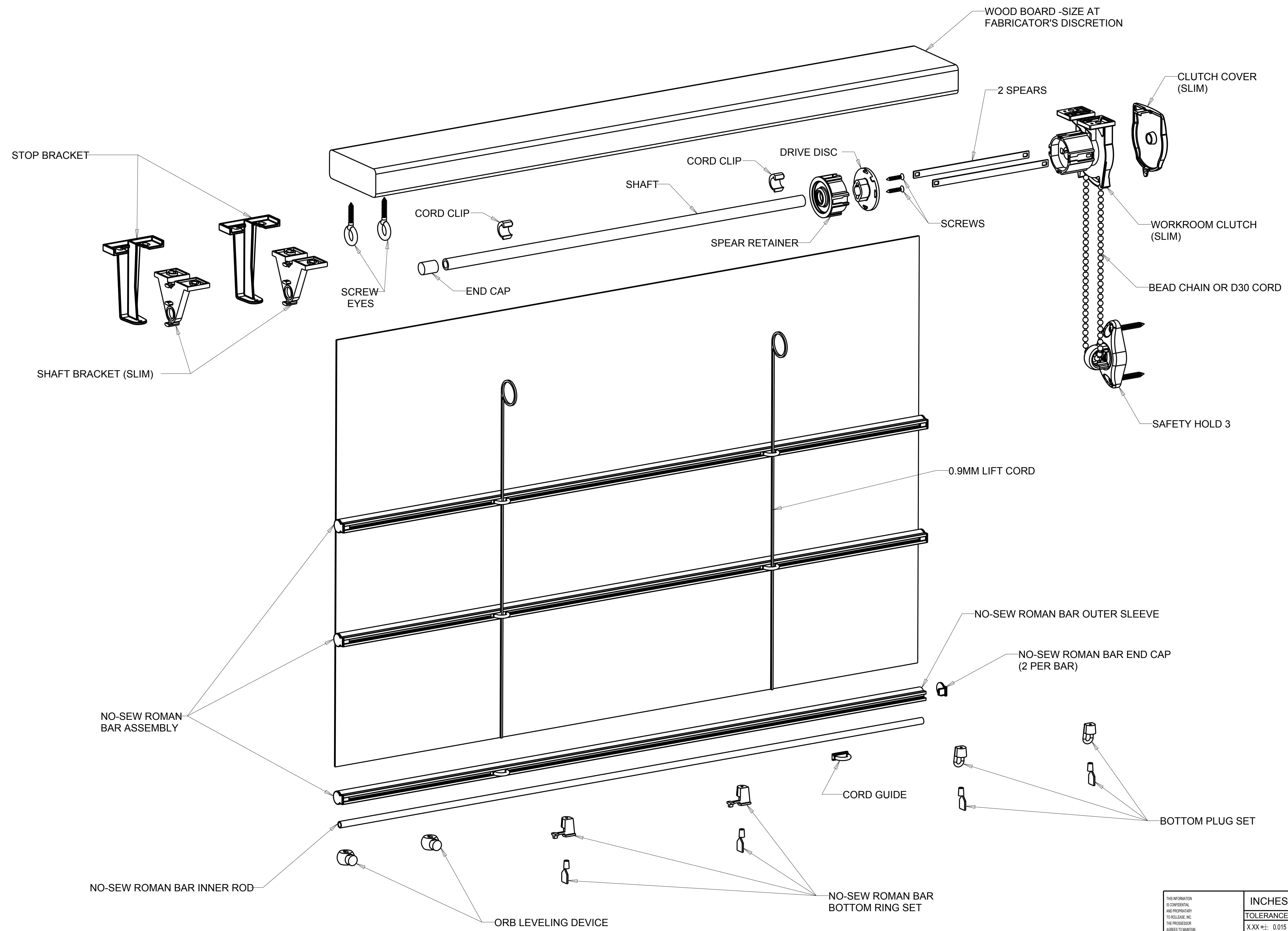

<small>THIS INFORMATION IS CONFIDENTIAL AND PROPRIETARY TO ROLL EASE, INC. THE POSSESSOR AGREES TO MAINTAIN THIS INFORMATION AS CONFIDENTIAL, NOT REPRODUCE OR DISSEMINATE IN WHOLE OR IN PART TO ANY THIRD PARTY.</small>	INCHES	<b>RollEase</b> Window Covering Systems		
	TOLERANCES	<small>XXX ± 0.015</small> <small>XXXX ± 0.005</small> <small>ANG ± 1°</small>	<small>DESIGNED BY</small> <small>TITLE</small> <small>DATE</small>	<small>SCALE</small> <small>ENGINEERING DRAWING NUMBER</small> <small>REV</small>
	<small>DATE</small> <b>16MAY13</b>	<small>DESIGNED BY</small> <b>RAE</b>	<small>TITLE</small> <b>WORKROOM SYSTEM-SLIM</b>	<small>SCALE</small> <b>1.3</b>
	<small>DATE</small> <b>16MAY13</b>	<small>SCALE</small> <b>D</b>	<small>ENGINEERING DRAWING NUMBER</small> <b>W174P028-S</b>	<small>REV</small> <b>1</b>

REVISION RECORD				
SYM	DESCRIPTION	BY	DATE	CHK

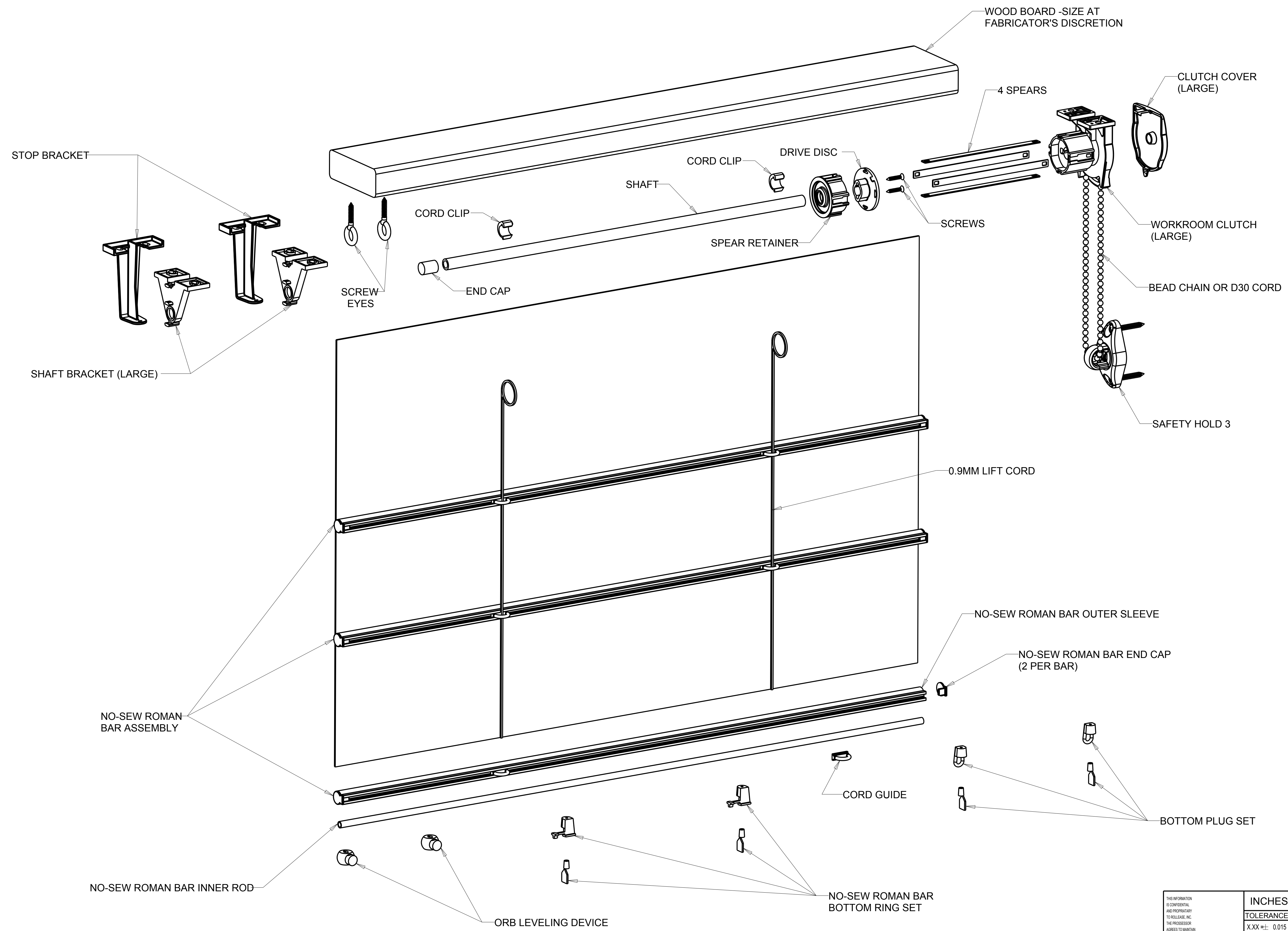

<small>THIS INFORMATION IS CONFIDENTIAL AND PROPRIETARY TO ROLL EASE, INC. THE POSSESSOR AGREES TO MAINTAIN THIS INFORMATION AS CONFIDENTIAL, NOT REPRODUCE OR DISSEMINATE IN WHOLE OR IN PART TO ANY THIRD PARTY.</small>	INCHES	<b>RollEase</b> Window Covering Systems		
	TOLERANCES			
	X.XXX ± 0.015	<small>DESIGNED BY</small> XXX	<small>TITLE</small> XXX	<small>SCALE</small> 1:1
	X.XXXX ± 0.005	<b>XXX WORKROOM SYSTEM-LARGE 1.3</b>		
ANG ± 1°	<small>DATE</small> 16MAY13	<small>SIZE</small> D	<small>ENGINEERING DRAWING NUMBER</small> W174P028-L	<small>REV</small> 1