

OVERVIEW: RB09 CHAIN CONTROL S45 SYSTEM

Step into the future with Acmeda's flagship RB09 chain control system. Utilising the very latest in technology, the RB09 brings over twenty years of experience into one cutting-edge design. The RB09 sets the benchmark for performance, function and aesthetics, with faster assembly time, easy installation, best in class operation and a slender, high gloss finish. With a wide range of options and add-on features, the RB09 is one of the most comprehensive manual roller systems on the market.

AESTHETIC FEATURES

- High polish finish
- Reduced light gaps

ASSEMBLY / INSTALLATION BENEFITS

- New two piece snap-lock winder assembly
- Reduce chain assembly time by up to 75%
- 10mm plastic Idler pin, extendable in 1mm increments.
- Comfort grip release wheel
- Advanced snap lock booster fitment
- Self-locating installation feature (see figure 1.1)

FUNCTIONAL BENEFITS

- Smoother operation
- Increased load capacity
- Patent protected

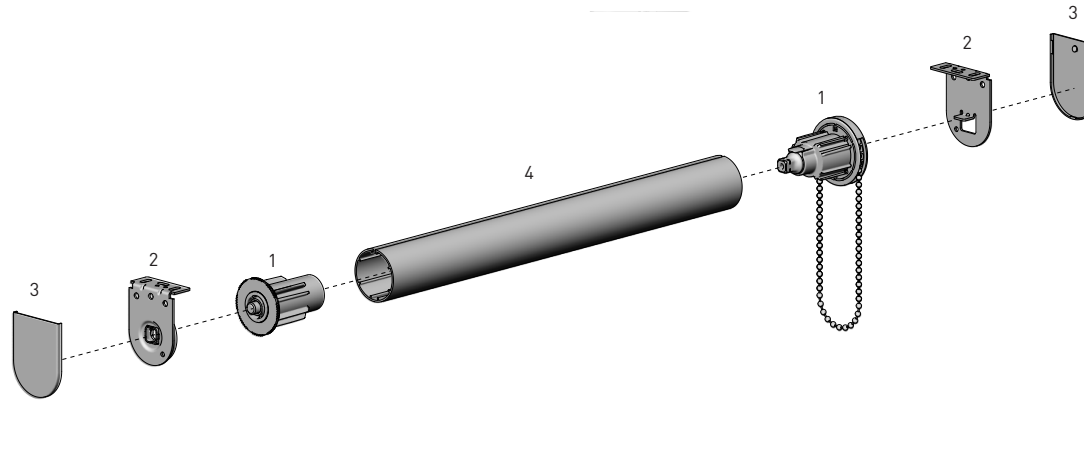
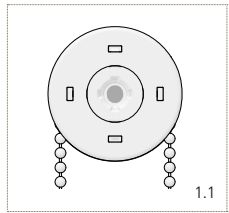

SYSTEM INDEX

- 1 RB09 Chain Winder & Extended Idler - S45
RB09-4501-xxx000
- 2 LX | Easy-Lock Installation Bracket - 40 & 55p
RB09-0351-xxx0##
- 3 LX / VX Bracket Cover Cap - 40 & 55p
RB08-4151-xxx0##
- 4 Aluminium Tube - S45 (LIGHT / STANDARD / HD)
RB93-044#-000580

xxx= colour

= size

COLOUR RANGE

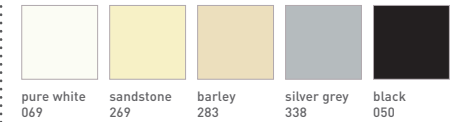

SYSTEM OPTIONS

MOUNTING RAIL

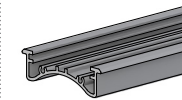

EASY-LIFT SPRING ASSIST BOOSTER



COMBO BRACKET

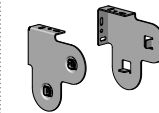

ADD ON SYSTEMS

FRS100 VALANCE SYSTEM

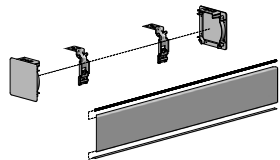

EASY-LINK S45

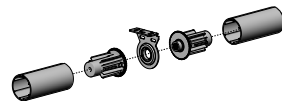

SQUARE BOX 100

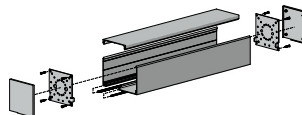

INTERNAL WIRE GUIDE



PELMET 95

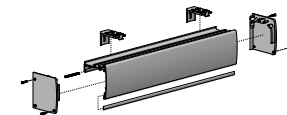

SPECIFICATIONS: RB09 CHAIN CONTROL S45 SYSTEM

SYSTEM CAPACITY

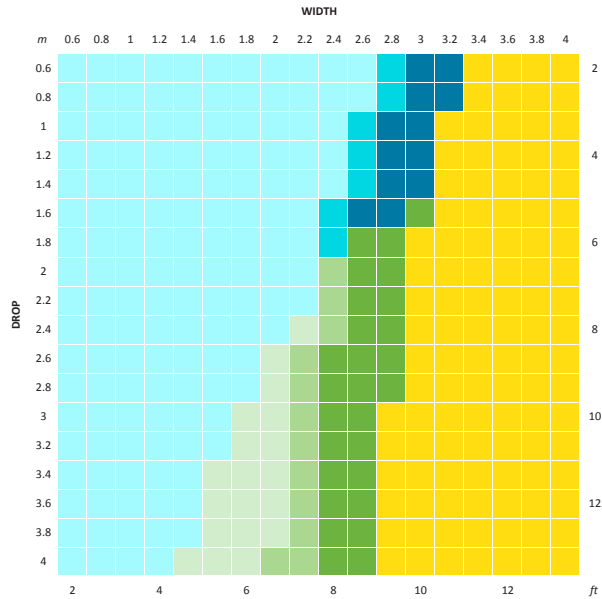

RB09 | Minimum Blind Width: 150mm / 6inches
 RB09 + RETROFIT | Minimum Blind Width: 1m / 39inches

CONTROL	LEGEND	DESCRIPTION	EASY-LINK REQ.
RB09	[Light Blue]	S45 HD / STD / LT	
	[Medium Blue]	S45 HD / STD	
	[Dark Blue]	S45 HD	
RB09 + RETROFIT	[Light Green]	S45 HD / STD / LT	
	[Medium Green]	S45 HD / STD	
	[Dark Green]	S45 HD	

*Refer to S40 / 45 Easy-Link QRG for further details

Parameters

Fabric Density: 420gsm
 Fabric Thickness: 0.6mm
 Weight Bar: D30 Bottom Rail

Maximum Hold Weights

S45 Light Tube: 4.7kg / 10.3 pounds (RB09), 13.4kg / 30 pounds (RB09 + Booster)
 S45 STD Tube: 4.6kg / 10 pounds (RB09), 13.0kg / 29 pounds (RB09 + Booster)
 S45 HD Tube: 4.2kg / 9.2 pounds (RB09), 11.8kg / 26 pounds (RB09 + Booster)

MAX ROLL

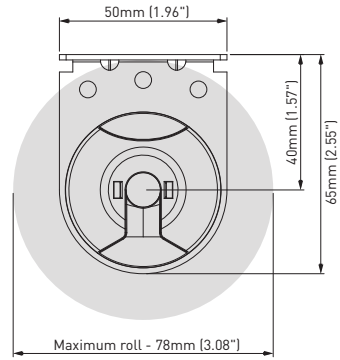

DEDUCTIONS

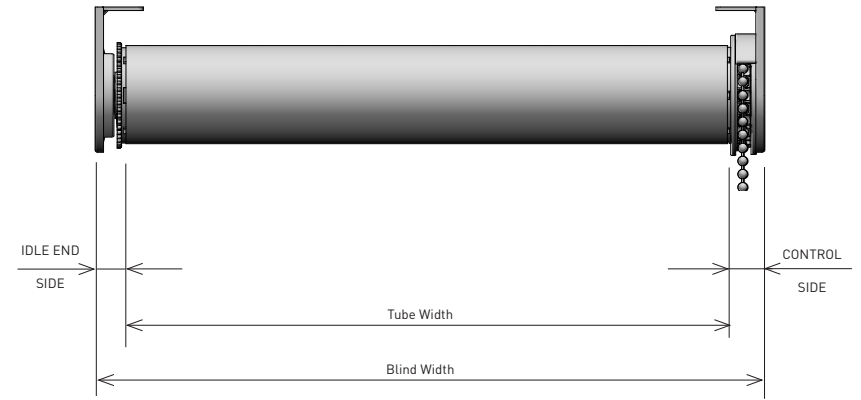

	IDLE END SIDE	CONTROL SIDE	OVERALL DEDUCTION
LX BRACKETS - with covers	14mm [0.55"]	15mm [0.59"]	29mm [1.14"]
LX BRACKETS - withOUT covers	13mm [0.51"]	13mm [0.51"]	26mm [1.02"]

ALUMINIUM TUBES

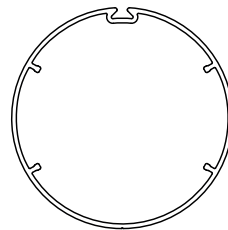

S45 LIGHT

T-Spline Tube

CODE: RB93-0443-000580
 RB93-6443-000580 (with D/S tape)
 O.D: 43mm
 Length: 5.8metres

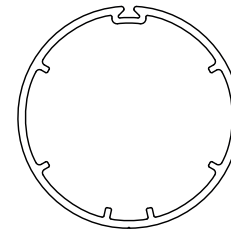

S45 STANDARD

T-Spline Tube

CODE: RB93-0444-000580
 RB93-6444-000580 (with D/S tape)
 O.D: 44mm
 Length: 5.8metres

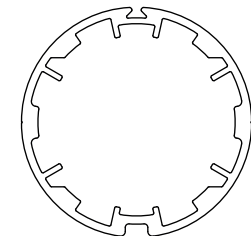

S45 HEAVY DUTY

T-Spline Tube

CODE: RB93-0449-000580
 RB93-6449-000580 (with D/S tape)
 O.D: 49mm
 Length: 5.8metres