



EXTREME WIRE GUIDE S100

INSTALLATION MANUAL



CONTENTS

- SECTION 1 | TOOLS, ADDITIONAL & NON-STOCKED ITEMS REQUIRED** 3
- EXTREME WIRE GUIDE - INSTALLATION OPTIONS4
- EXTREME WIRE GUIDE - COMMON ITEMS CHECKLIST5
- SECTION 2 | PREPARING INSTALLATION SPACE** 6
- VERTICAL DIMENSIONS6
- HORIZONTAL DIMENSIONS6
- SECTION 3 | INSTALLATION** 7
- MOUNTING BRACKETS/BOX190 ASSEMBLY7
- MOUNTING WIRE GUIDE TERMINALS9
- TUBE ASSEMBLY11
- WEIGHT BAR ASSEMBLY12
- TENSION THE WIRE13
- SECTION 4 | FINALISE ASSEMBLY** 14
- BOX 190 FRONT COVER14
- TEST RUN INSTALLATION TO ASSESS WIRE TENSION14
- SECTION 5 | DUAL INSTALLATION** 15
- SIDE BY SIDE.....15
- SECTION 6 | TROUBLE SHOOTING** 16
- FREQUENTLY ASKED QUESTIONS16

DISCLAIMER

This manual is produced by Rollease Acmeda to supply the necessary information to ensure the safe and correct assembly, installation & operation of the hardware referenced.

COPYRIGHT © ROLLEASE ACMEDA

All rights are reserved. No part of this document may be reproduced or utilised in any means, by any means, electronic or mechanical including photocopying, recordings, or by any information storage or retrieval system, without the express permission from Rollease Acmeda.



TOOLS REQUIRED

To assemble an Extreme system the following tools are required:

- Drills & bits (inc. masonry bits)
- Measuring Tape
- Flat & Phillips head screw drivers
- Wrench set
- Plumb bob or equivalent
- Allen key set
- Mallet
- Level
- Hydraulic swaging tool
- Stainless steel wire cutter

NOTE: Tools required may vary depending on installation conditions, fastening surfaces, etc.

ADDITIONAL ITEMS REQUIRED

Fasteners for fixing. Ensure appropriate fixings are used to suit applications.

Spare wire guide crimp terminals to allow for wire guide assembly errors (Hydraulic crimp terminals cannot be re-used)

To assemble an Extreme system the following non-stocked items are required:

- Staples (6mm x 1/4" Heavy Duty)
- Fabric
- M10 Button Head Screw S/S (to suit tensioning body on face fix bracket)
- Appropriate fixings to suit application
- Spare wire guide crimp terminals to allow for wire guide assembly error

EXTREME WIRE GUIDE - INSTALLATION OPTIONS

BRACKETS

BOX190 CASSETTE

Installation Specific Items

1. Box 190 Assembly
2. Box 190 Front Cover Assembly
3. Complete Shade

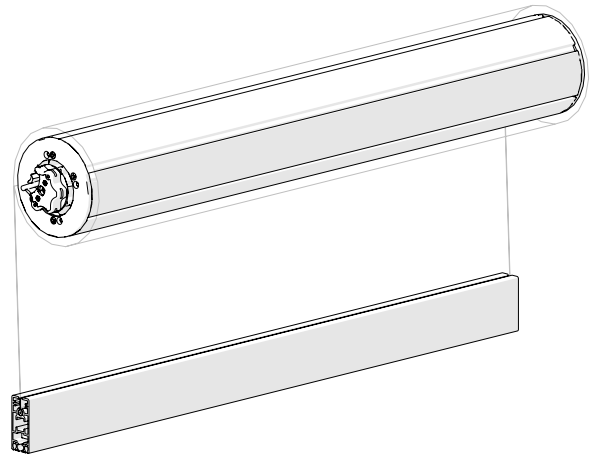
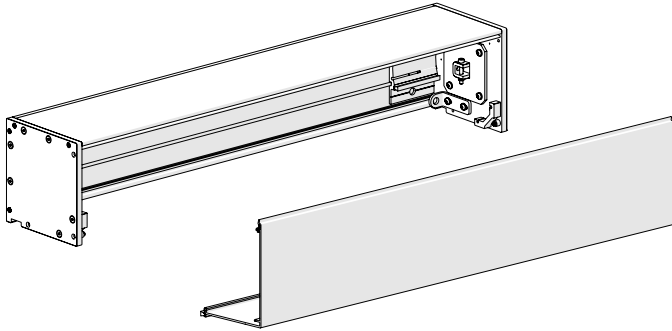

OPEN BRACKETS

Installation Specific Items

1. Brackets
2. Complete Shade

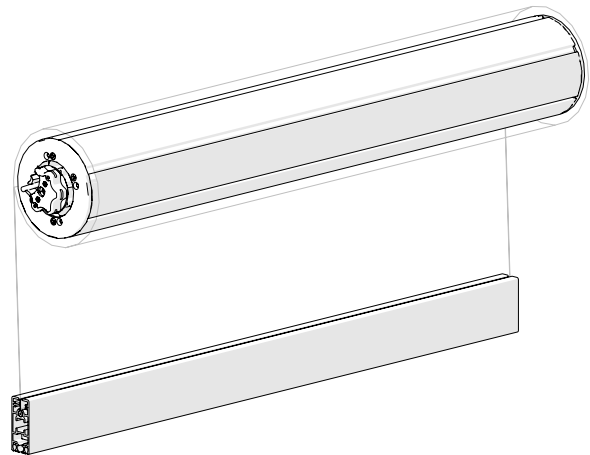
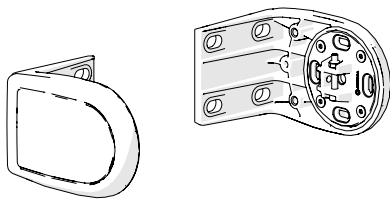

RECESS FIT BRACKETS

Installation Specific Items

1. Brackets
2. Complete Shade

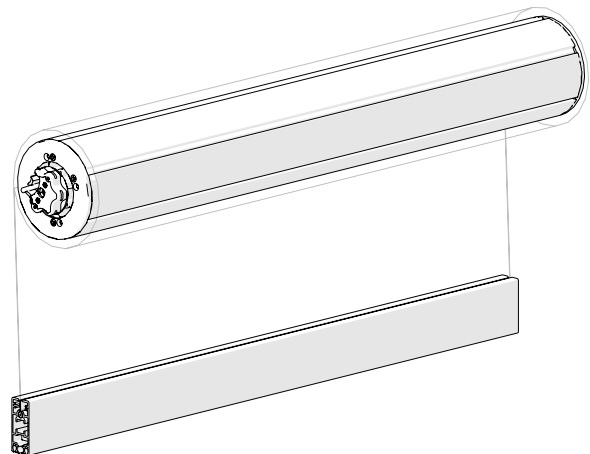
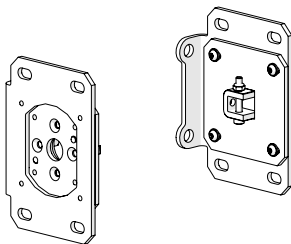

EXTREME WIRE GUIDE - COMMON ITEMS CHECKLIST

Check that you have all shade items

1. Stainless Steel Wire SS316 - 4mm
2. Fork Swage Terminal
3. Wire Guide Adapter Kit (Ceiling/Wall Bracket Only)
4. Bottom Bar End Caps
5. Wire Guide Floor/Wall Mounting Kit

1. Stainless Steel Wire

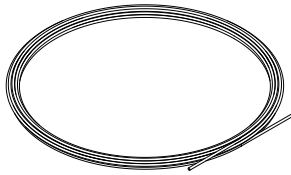

2. Fork Swage Terminal

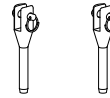

3. Wire Guide Adapter Kit (Ceiling/Wall Bracket Only)

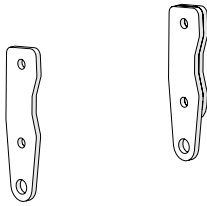

4. Bottom Bar End Caps

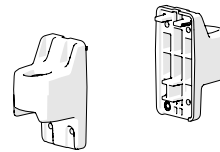

5. Wire Guide Floor/Wall Mounting Kit

Tensioning Bracket

Floor Fix

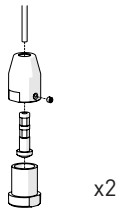

x2

Stud Terminal

Top/Face Fix

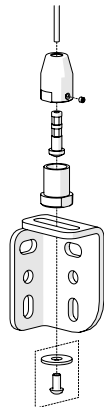

x2

Stud Terminal with Spring

Side/Face Fix

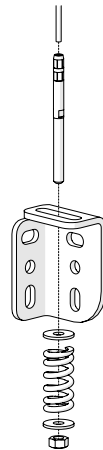

x2

Tensioning Bracket

Side/Face Fix

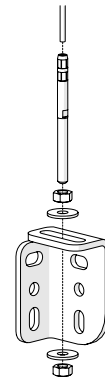

x2

VERTICAL DIMENSIONS

STEP 1 - CHECK VERTICAL INSTALLATION DIMENSIONS AT EACH END

NOTE:

- Avoid installing Extreme in windy conditions.
- Check for any obstructions that may interfere with installation.
- This may mean the installer needs to take steps to prepare the space prior to commencement of installation.

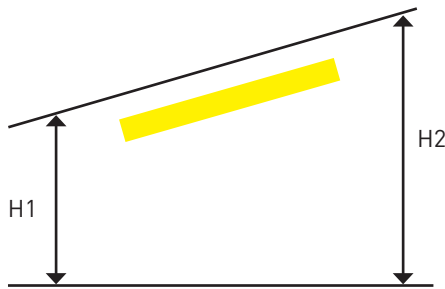

Check if top of installation space is level.

STEP 2 - CHECK VERTICAL INSTALLATION DIMENSIONS AT EACH END

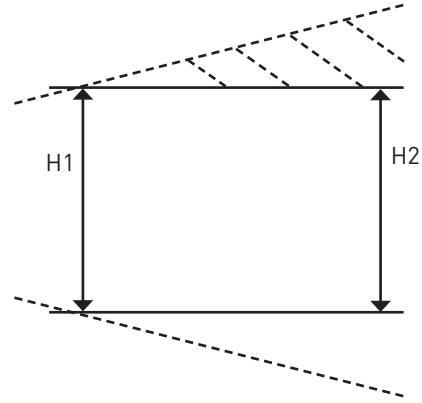

For Top Fix systems, consider corrective options prior to commencing installation to ensure the blind can be installed level.

HORIZONTAL DIMENSIONS

STEP 1 - CHECK HORIZONTAL INSTALLATION DIMENSIONS AT TOP & BOTTOM

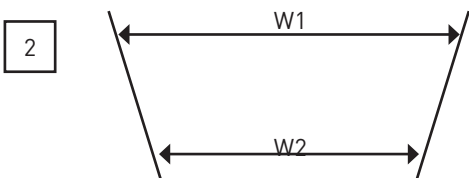
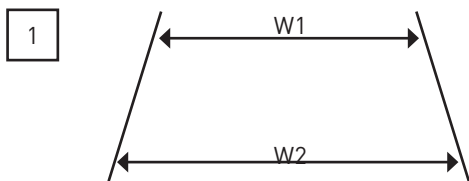

If difference between W1 and W2 is greater than 5mm (0.197"), pack out installation space as required.

If W1 and W2 are within 5mm (0.197") proceed with installation.

STEP 2 - END CAP INSTALLATION FLOAT

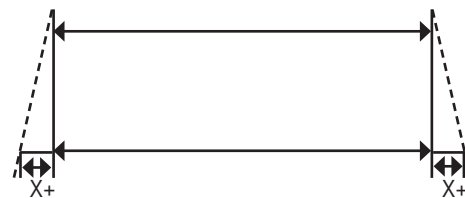

Determine what the dimension of x is on each side.

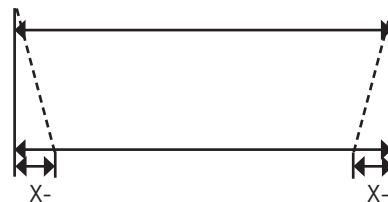

If adjustment range is adequate proceed with installation, if not consider further options for squaring out the installation space (such as packing or other).

END CAP FLOAT	X
	± 5mm (0.20")

SECTION 3 | INSTALLATION

MOUNTING BRACKETS/BOX190 ASSEMBLY

INSTALL IN DESIRED LOCATION USING APPROPRIATE FIXINGS TO SUIT SURFACE

[Refer to deductions for bracket positioning]
 Ensure brackets are installed aligned and level.
 Holes for M10 Std size fastener - images indicative only.

TOP FIX

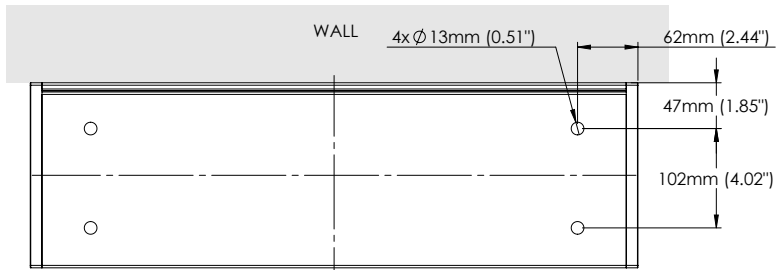
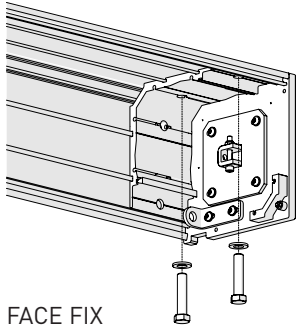

FACE FIX

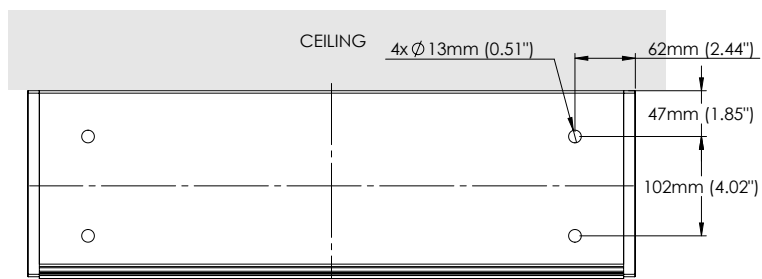
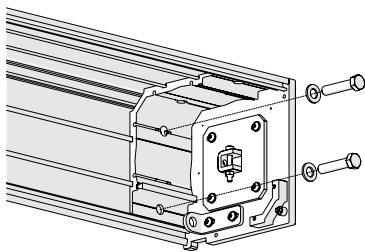

SIDE FIX

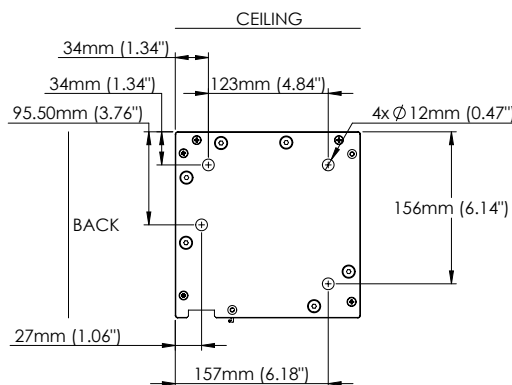
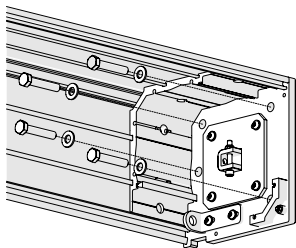

RECESS / SIDE FIX BRACKET

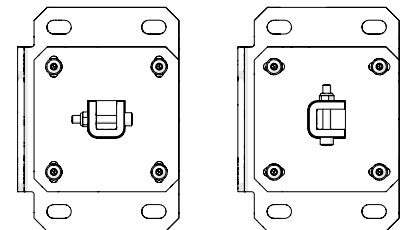
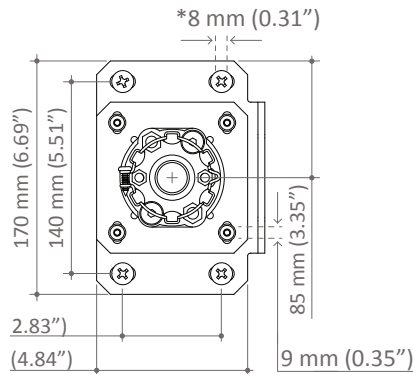
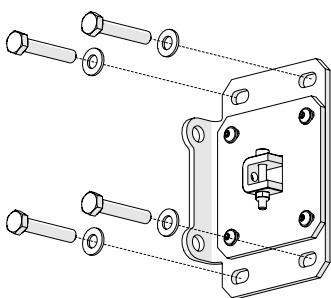

Check clearance for tube assembly and rotate idler assembly as required.

NOTE:
 Bracket Mounting Holes for M10 Std size fastener - images indicative only.

MOUNTING BRACKETS/BOX190 ASSEMBLY

FACE & TOP FIX BRACKET

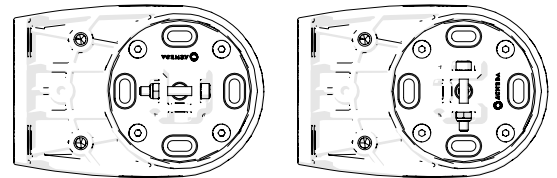
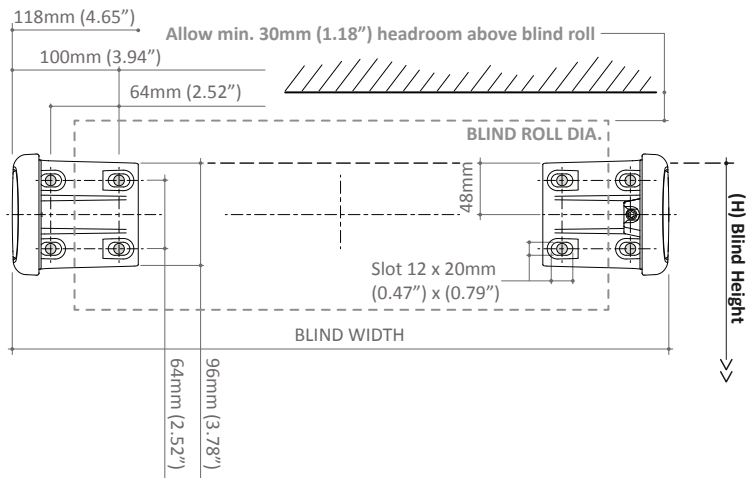
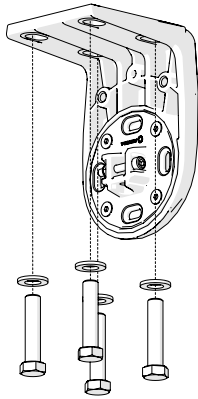
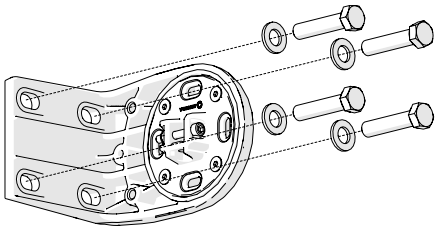

NOTE:
 Bracket Mounting Holes for M10 Std size
 fastener - images indicative only.

Check clearance for tube assembly and rotate idler
 assembly as required.

ASSEMBLE WIRE GUIDE ADAPTOR(S) TO BRACKETS

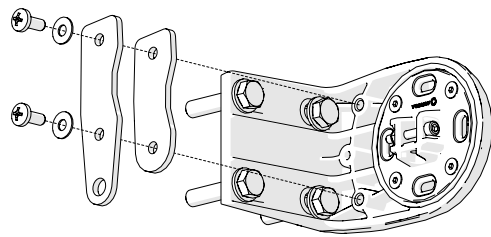
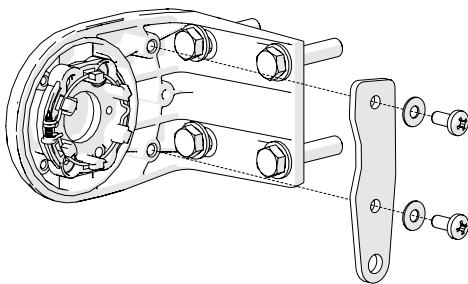

MOUNTING WIRE GUIDE TERMINALS

STEP 1 - MARK OUT & PREPARE THE WIRE GUIDE BRACKET FIXING POINTS

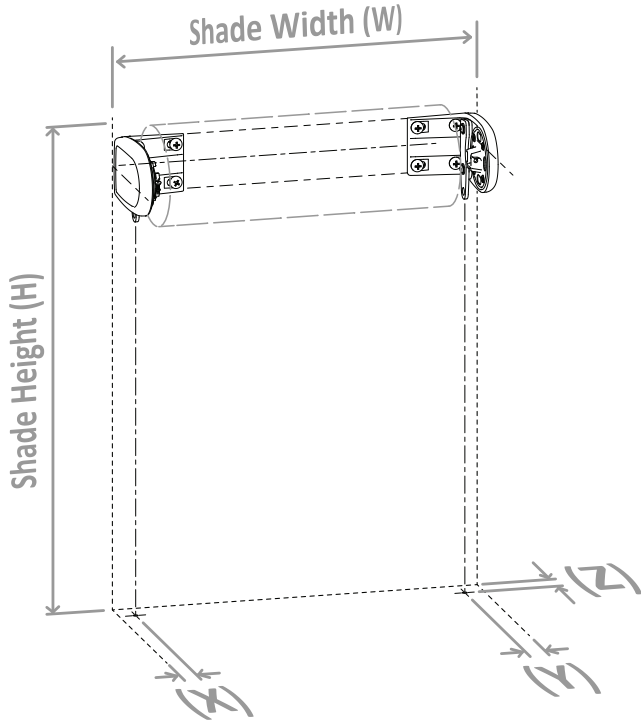

STEP 2 - SECURE TENSIONING BRACKET TO FLOOR/WALL

FLOOR FIX

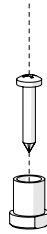

FACE FIX

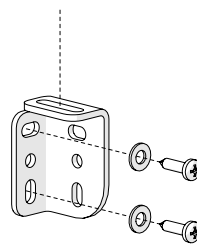

SIDE FIX

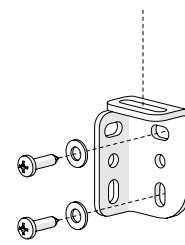

ASSEMBLED

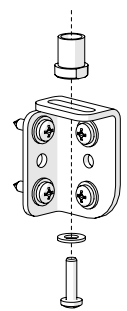

Note: Refer to deduction section for correct wire guide centres. Note: Terminal assembled to bracket with M10 Screw & Washer.

STEP 3 - PREPARE WIRE ASSEMBLIES

TENSIONING BRACKET - FLOOR / SIDE / FACE FIX

Crimp Top:
See Crimp Spec.

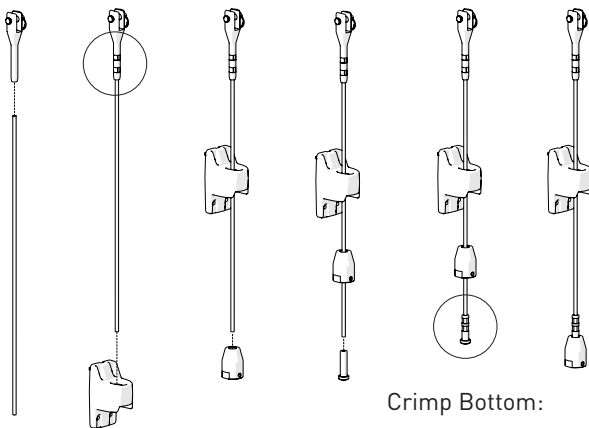

Crimp Bottom:
See Crimp Spec.

STUD TERMINAL - SIDE / FACE FIX

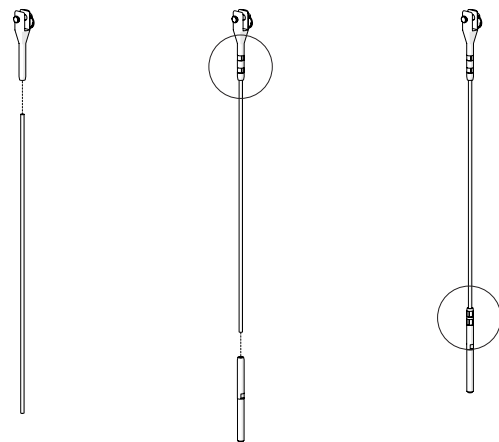

Crimp Top:
See Crimp Spec.

Crimp Bottom:
See Crimp Spec.

Note:
Refer to deductions for theoretical cable lengths.
Measure, cut & crimp wire on site to validate & ensure correct cable length.

Note:
Refer to deductions for theoretical cable lengths.
Measure, cut & crimp wire on site to validate & ensure correct cable length.

MOUNTING WIRE GUIDE TERMINALS

MINIMUM CRIMP SPECIFICATIONS

a) Ensure cable is fully inserted into terminal

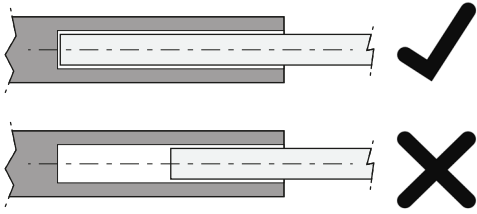

b) Ensure 2x crimps minimum per terminal.

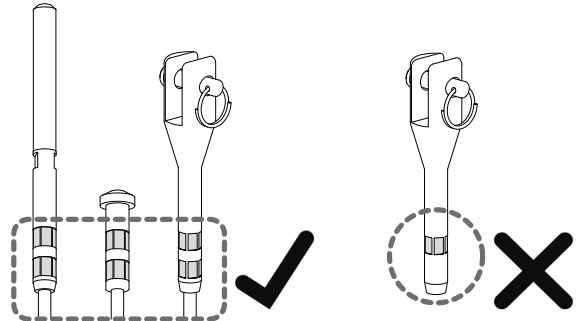

c) Crimp guide - refer to tools section for recommended crimp tool.

Refer to table below for guide of crimp position and sizing for all terminals.

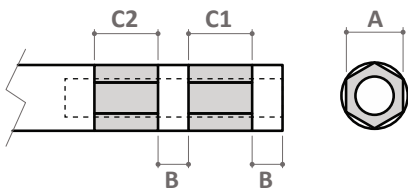

Item	Size (mm)	Size (in)
A (Crimp Hex AF)	6.5	0.26"
B (Crimp spacing)	3.0	0.12"
C1/C2 (Crimp length)	7.5	0.30"

NOTE: Ensure jaws of crimp tool close completely to achieve maximum possible crimp strength - use dimension A as a guide.

STEP 4 - ATTACH FORK TERMINAL (CRIMPED) TO WIRE GUIDE ADAPTOR

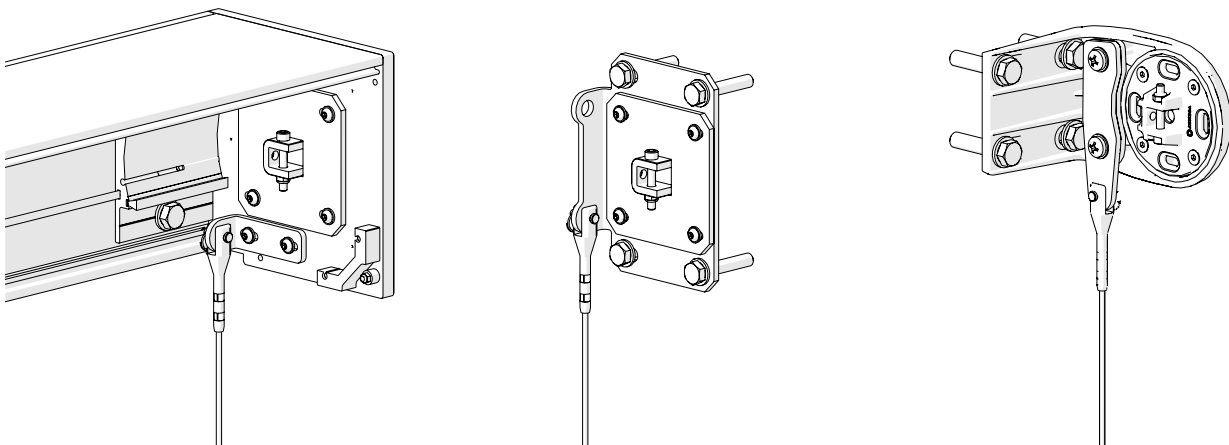

TUBE ASSEMBLY

STEP 1 - REMOVE RETAINING FASTENERS FROM CONTROL & IDLER ENDS

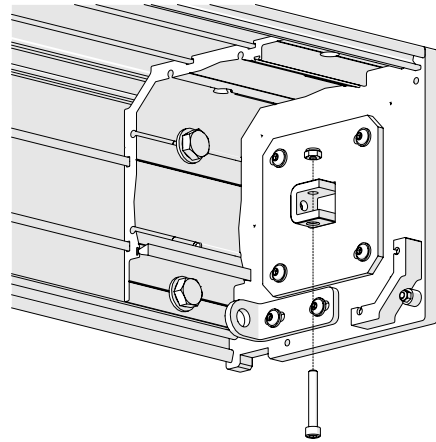
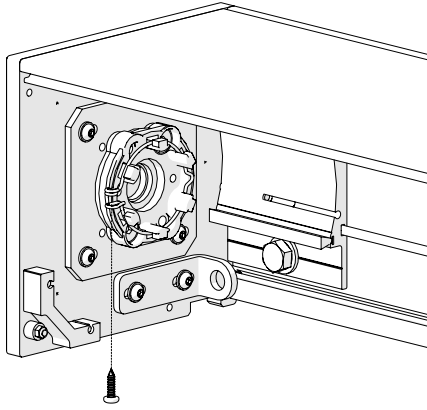

NOTE:
BOX 190 shown but same process for all brackets.

STEP 2 - INSTALL SHADE ASSEMBLY ONTO THE BRACKETS - INSERT CONTROL END FIRST

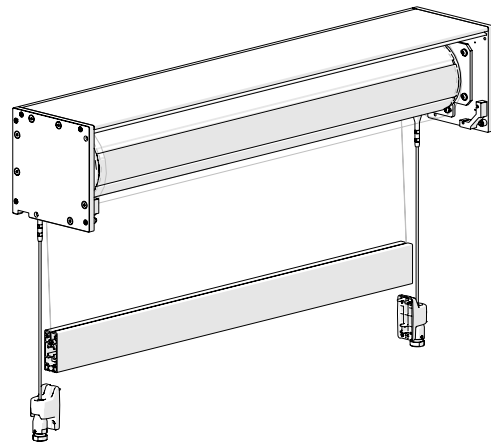
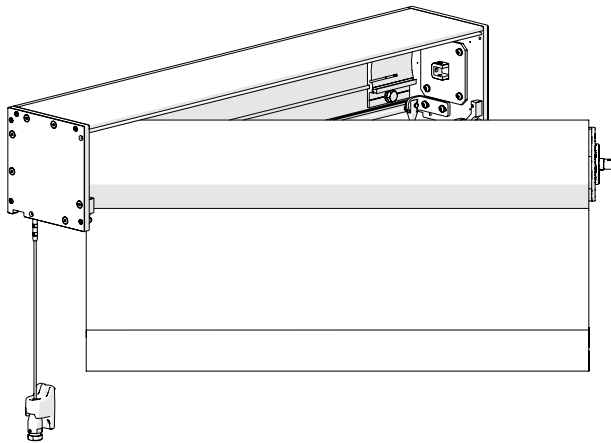

NOTE:
BOX 190 shown but same process for all brackets.

STEP 3 - REATTACH FASTENERS TO CONTROL & IDLER ENDS

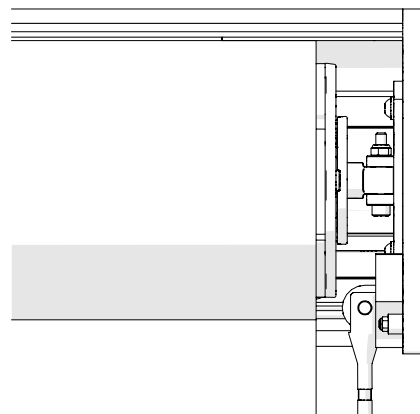
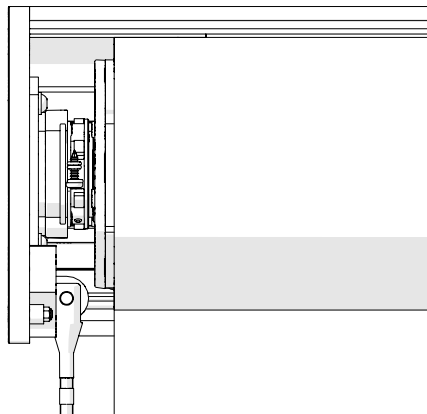

NOTE:
BOX 190 shown but same process for all brackets.

WEIGHT BAR ASSEMBLY

ASSEMBLE WEIGHT BAR END CAPS THAT ARE ALREADY ATTACHED TO GUIDE WIRE

Ensure wire guide cables are loose.

(Apply with firm pressure)

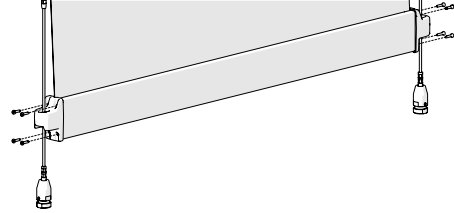
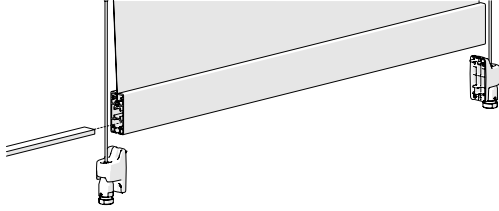

NOTE:

If ballast is required, insert prior to fitting end cap.

For external applications ensure ballast is treated for corrosion resistance and is compatible with aluminium.

ASSEMBLE STUD TERMINAL WASHERS & NUTS WITH SPRING

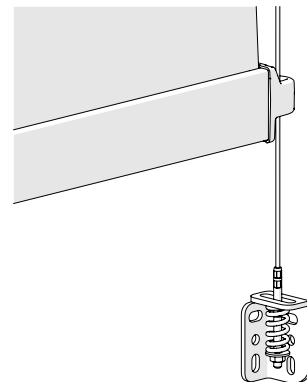
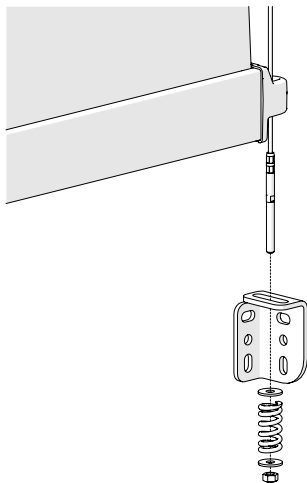

ASSEMBLE STUD TERMINAL WASHERS & NUTS

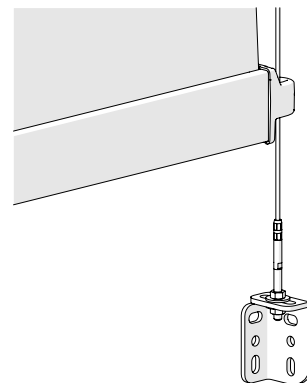
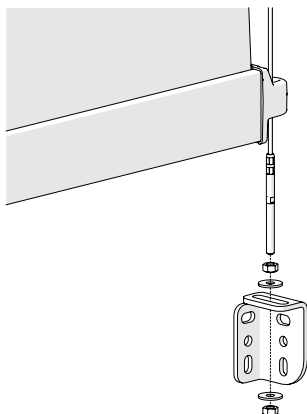

TENSION THE WIRE

TENSION GUIDELINES

Recommended tension force for Extreme 4mm wire guide system is 700 - 900N Maximum. (70 - 90Kgf)

In the absence of a suitable tension meter, refer to the tension charts for guide lines on the No. of fastener turns (or travel) required to achieve desired tension.

The number of fastener turns or amount of stretch is relative to the length of the wire guide.

OPTION 1: Tension Bracket		
Wire Length	No. of turns Tension Body (A) (min) – (max)	Travel (mm)
2.5m (8.2')	1.0 – 1.5x	1.5 – 2.0mm (0.059" – 0.079")
5.0m (16.4')	2.0 – 3.0x	2.5 – 3.5mm (0.098" – 0.138")

OPTION 2: Terminal Stud		
Wire Length	No. of turns M8 Nut (min) – (max)	Travel (mm)
2.5m (8.2')	1.0 – 1.5x	1.5 – 2.0mm (0.059" – 0.079")
5.0m (16.4')	2.5 – 3.0x	3.0 – 4.0mm (0.118" – 0.157")
7.5m (24.6')	4.0 – 5.0x	4.5 – 6.0mm (0.177" – 0.236")
10.0m (32.8')	5.0 – 6.5x	6.0 – 8.0mm (0.236" – 0.315")

When using the tension spring, take note of the spring length prior to compressing the spring to apply tension in the wire system. Refer to the table for a guide on amount of spring compression and/or fastener turns required to achieve desired tension.

The wire length is not relevant for this tension method as the spring will apply the required tension once compressed to the nominated state.

OPTION 3: Terminal Stud with Spring		
Tension	Spring Compression mm	*No. of turns M8 Nut.
700 N min.	6.0mm (0.236")	5.0x
900 N max.	8.0mm (0.315")	6.5x

* Note, count number of turns from point spring begins to compress.

USING A SPANNER, HOLD B & ROTATE A TO APPLY TENSION ON THE CABLE

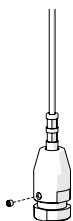
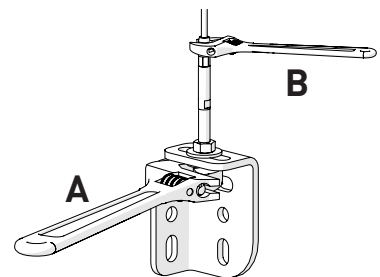
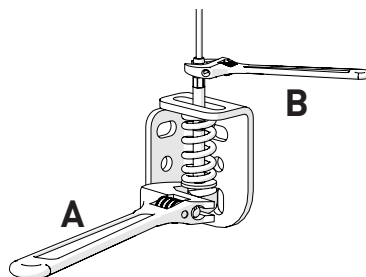
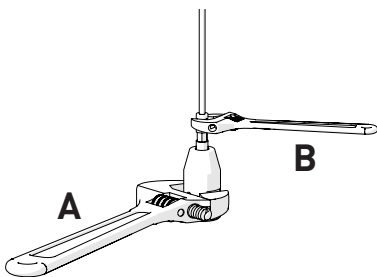

When sufficiently tensioned, tighten the grub screw with an Allen key to lock the fitting and prevent loosening of the cable.

BOX 190 FRONT COVER

ATTACH & FIX FRONT COVER WITH SELF TAPPING SCREWS

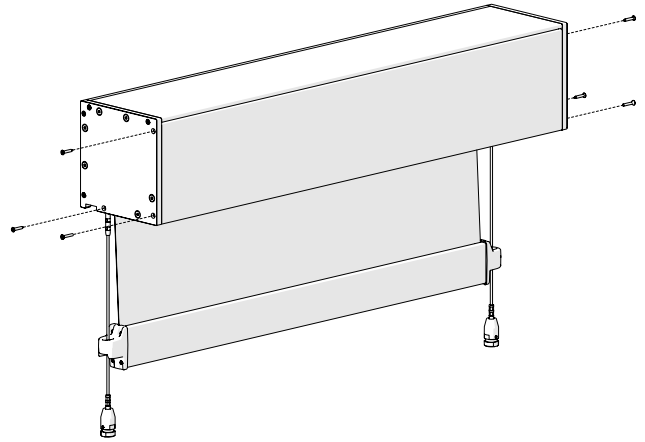
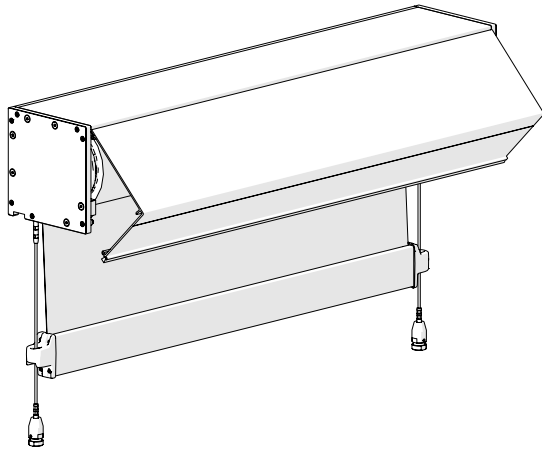

TEST RUN INSTALLATION TO ASSESS WIRE TENSION

BOX 190

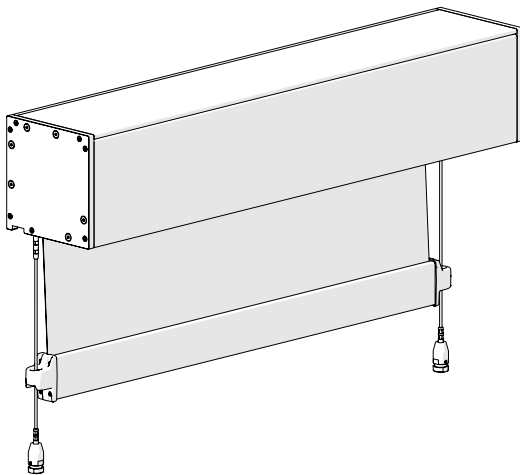

RECESS/SIDE FIX

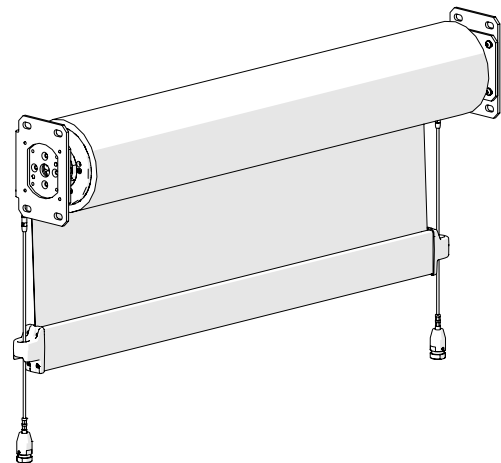

OPEN TOP FIX

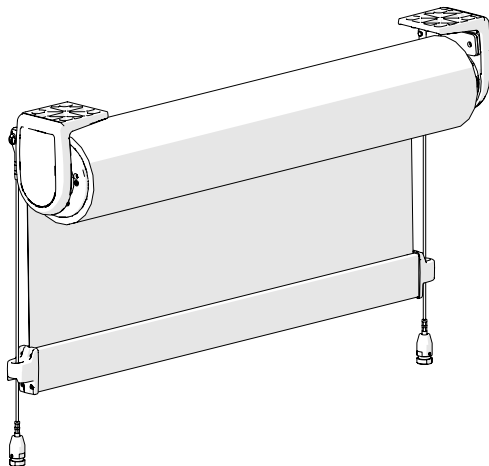

OPEN FACE FIX

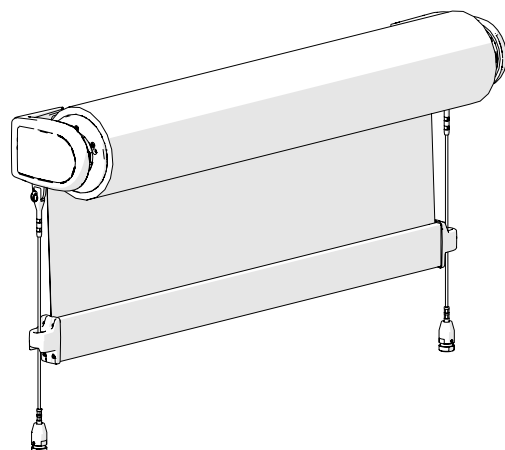

SIDE BY SIDE

Extreme blinds can be installed in multiple scenarios side by side.

The governing factor spacing of the blinds beside the Top/Face fix or Side Fix scenarios will be the wire guide fixing option.

Floor mounted Tensioning bracket for wire guides will determine the minimum spacing between blinds.

Consideration should be given to the anchor method and fixing surface for the tension bracket anchors in terms of minimum fixing centres between anchors.

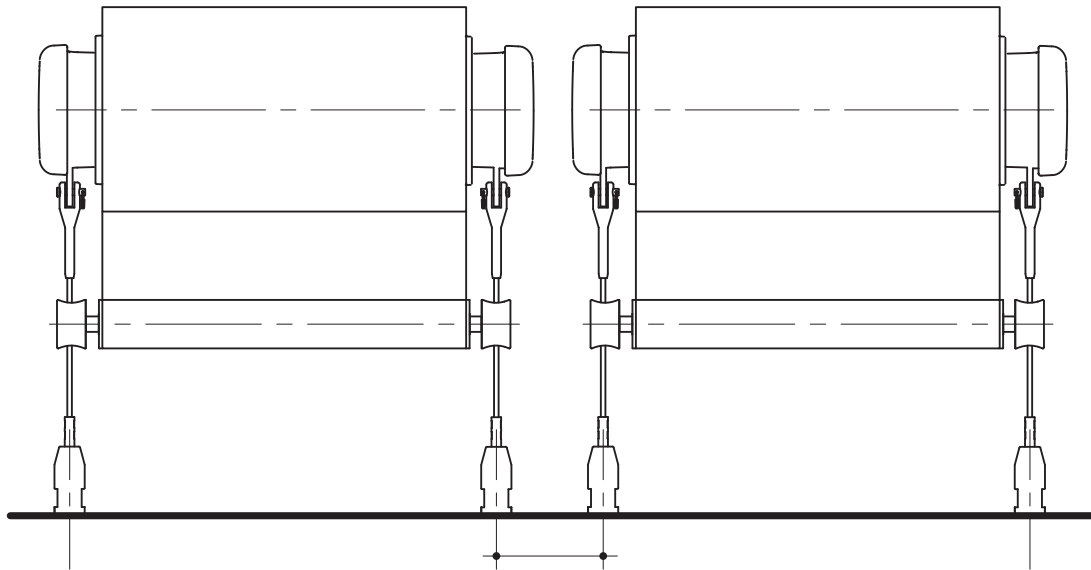

Min spacing: 130mm (5.12')
Refer to fastener manufacturers specifications.

FREQUENTLY ASKED QUESTIONS

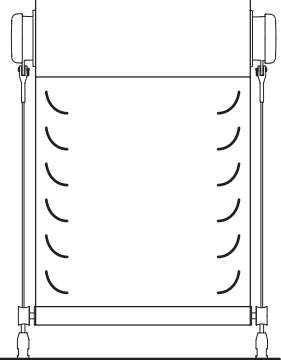
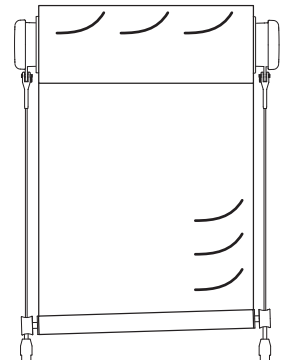
NO.	PROBLEM	CAUSE	SOLUTION
1	<p>Ripples along sides of fabric.</p> 	Blind Rolled up for extended period of time.	This occurrence is inherent to roller systems and is more prevalent in some fabrics. Leave blind down for 1 – 4 hrs; most ripples should disappear.
		Not enough weight in weight bar.	Refer to product specs. Add ballast.
		Installation is not square.	Check blind roll is installed level.
		Fabric permanently damaged due to inadequate handling during assembly, transportation, installation or use.	Replace the fabric and ensure it is handled with care.
2	Blind does not full open or jams	Check motor stop limits	Refer to motor instructions to reset stop limits.
		Position of wire guides at base is incorrect.	Check if wire guide fixing at floor/base level are not positioned too far inboard. Adjust / reposition as required, refer to product spec for correct placement details.
3	<p>Uneven weight bar</p> 	Blind roll is not level, thus weight bar appears uneven	Ensure blind is installed level.
		Blind has been operated in excessive wind conditions.	Check blind rolled when the blind is fully raised. If ripples are evident on roll, open blind fully (without presence of wind) to allow the blind to track down evenly. Raise and lower blind a number of times to check operation.